

WHEEL STUDS

ARP's heat-treated 8740 chrome moly wheel studs are a much-needed replacement for any car engaged in oval track or drag racing competition. They have a tensile strength of **190,000 psi** and are able to easily handle the tremendous acceleration shock loads (shear) and lateral forces (elongation) found in racing. The studs are sold in packs of 5 and are cadmium plated for extra durability. Nuts not included. Now available for all popular applications, including General Motors, Ford, Honda and Chrysler replacements, as well as for oval track racing and aftermarket street and strip axles.

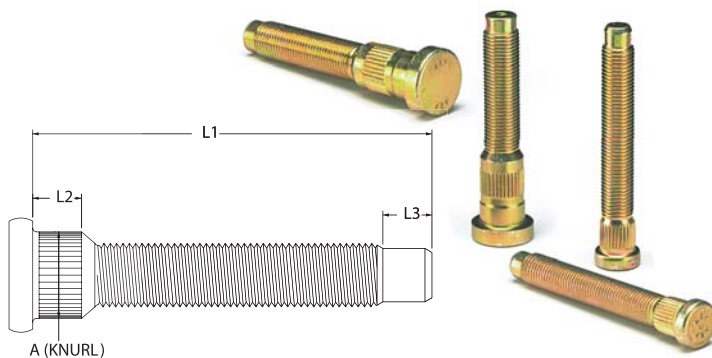

Application	A Knurl Dia.	L1 UHL	L2 Knurl Length	L3 Nose Length	Thread Size	Part No.
CHRYSLER						
Chrysler, rear	.680	3.125	.400	.400	1/2-20	100-7705
DODGE						
Neon, front	.585	2.450	.256	.360	M12 x 1.5	100-7721
FORD						
Ford, rear disc brakes/Chrysler front	.625	3.500	.400	.437	1/2-20	100-7703
Ford, front disc brakes, early	.618	3.050	1.000	.250	1/2-20	100-7707
Mustang II front	.554	3.435	.390	.435	1/2-20	100-7714
GM						
Late GM drum brake	.486	3.165	.420	.308	7/16-20	100-7701
Late GM disc brake and early drum brake	.580	3.200	.300	.305	7/16-20	100-7702
Late GM Camaro, Firebird, Corvette	.509	2.500	.315	none	M12 x 1.5	100-7708
Late GM Camaro, Firebird, Corvette	.509	3.250	.315	none	M12 x 1.5	100-7713
HONDA						
'80-'00 stk. replacement, 4 pack	.485	1.850	.275	.350	M12 x 1.5	100-7709
'80-'00 stk. replacement, 5 pack	.485	1.850	.275	.350	M12 x 1.5	100-7710
'80-'00, 4 pack	.485	2.850	.275	.350	M12 x 1.5	100-7711
'80-'00, 5 pack	.485	2.850	.275	.350	M12 x 1.5	100-7712
LEXUS						
IS 300	.558	2.600	.230	none	M12 x 1.5	100-7715
MAZDA						
Miata, front and rear '90-'93, front '94-'05	.507	2.750	.335	.350	M12 x 1.5	100-7719
Miata, rear '94-'05	.579	2.750	.300	.350	M12 x 1.5	100-7720
MITSUBISHI						
Lancer EVO VIII	.565	3.000	.270	.350	M12 x 1.5	100-7717
SUBARU						
WRX	.565	3.000	.270	.350	M12 x 1.25	100-7716
TOYOTA						
Celica GTS '86-'89 front	.565	2.340	.325	.363	M12 x 1.5	100-7718
OTHERS						
Aftermarket axles, 12 pt style head	none	3.470	none	.500	1/2-20	100-7704
Speedway Eng, Pro 4 disc	.568	2.970	.710	.465	1/2-20	100-7706

DRIVE PLATE BOLT KITS

Developed for racers who leave nothing to chance, ARP's special drive plate bolts have many important features, including use of a premium grade chrome moly alloy, heat-treating to **200,000 psi**, J-form thread rolling after heat-treat and a special profile. The bolts come with special precision-ground washers.



Application	UHL	Part No.
Wilwood drive plate bolt, 1.500, 12-point drilled, 8 pieces	1.500	200-3401

SPRINT CAR DRIVE PINS

ARP sprint car drive pins feature a broached hex for ease of installation and proper pre-load while the rounded end facilitates quick, positive wheel location. All critical shear points feature a large radius for improved reliability and maximum load carrying capacity. Drive pins are rated **200,000 psi** tensile strength.



Application	UHL	Part No.
Front, 2.450" OAL	1/2-20	200-2601
Rear, 3.275" OAL	1/2-20	200-2602

66 For use with Wilwood rear drive hub; also fits Speedway hubs.

