

**Step 1: Mounting plates**

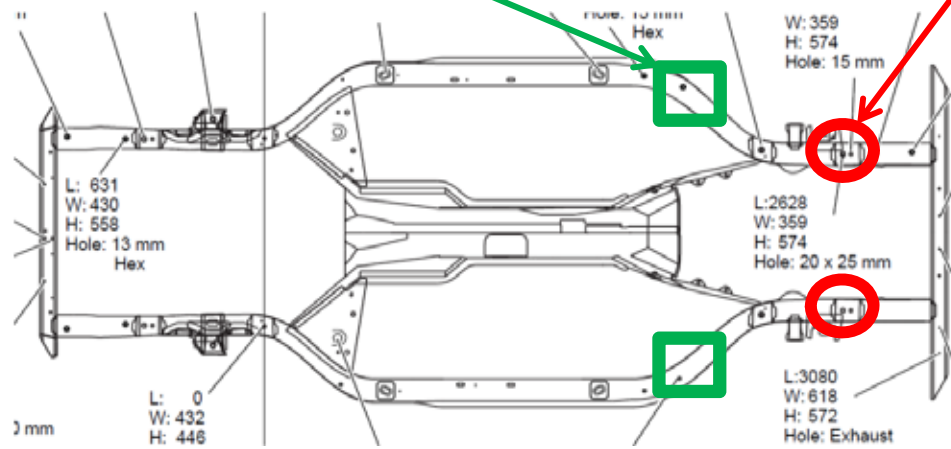

On the frame behind the B pillar, access through gas tank opening

On the frame in the trunk next to suspension mounts



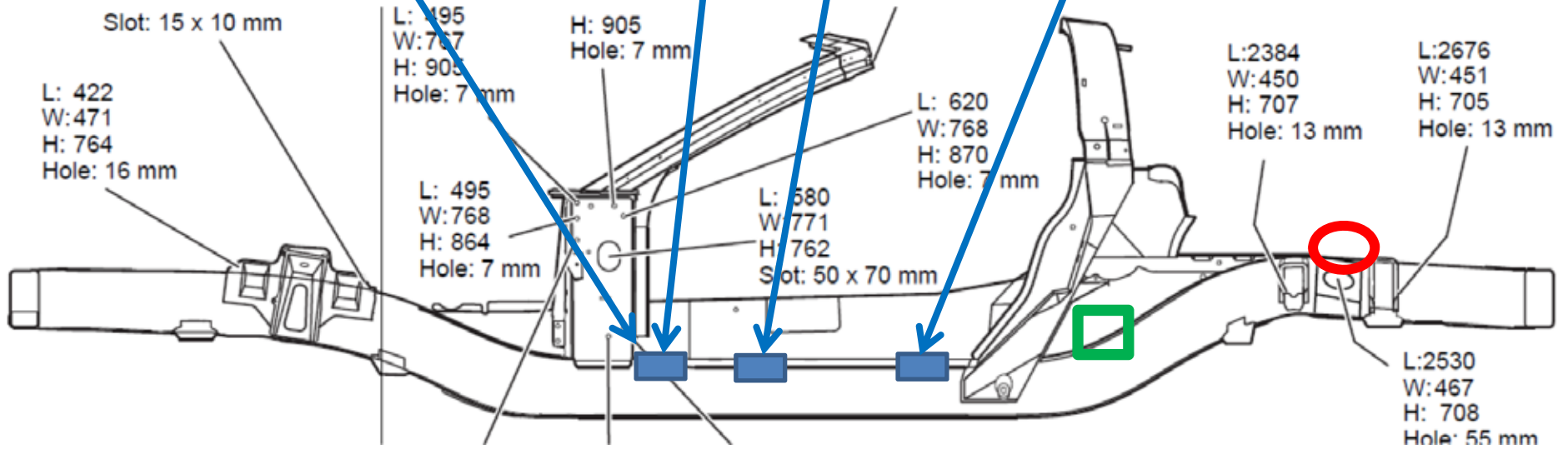

Step 2: Main hoop





Step 3: Cross bars



Step 4: Door bars



This options keeps the electric windows

Do not pay attention to the main hoop, this is not where you want to anchor it.







Windows have to be completely removed if bars are going that deep in the door



**Step 5: Dash bar**

**Net attachment**

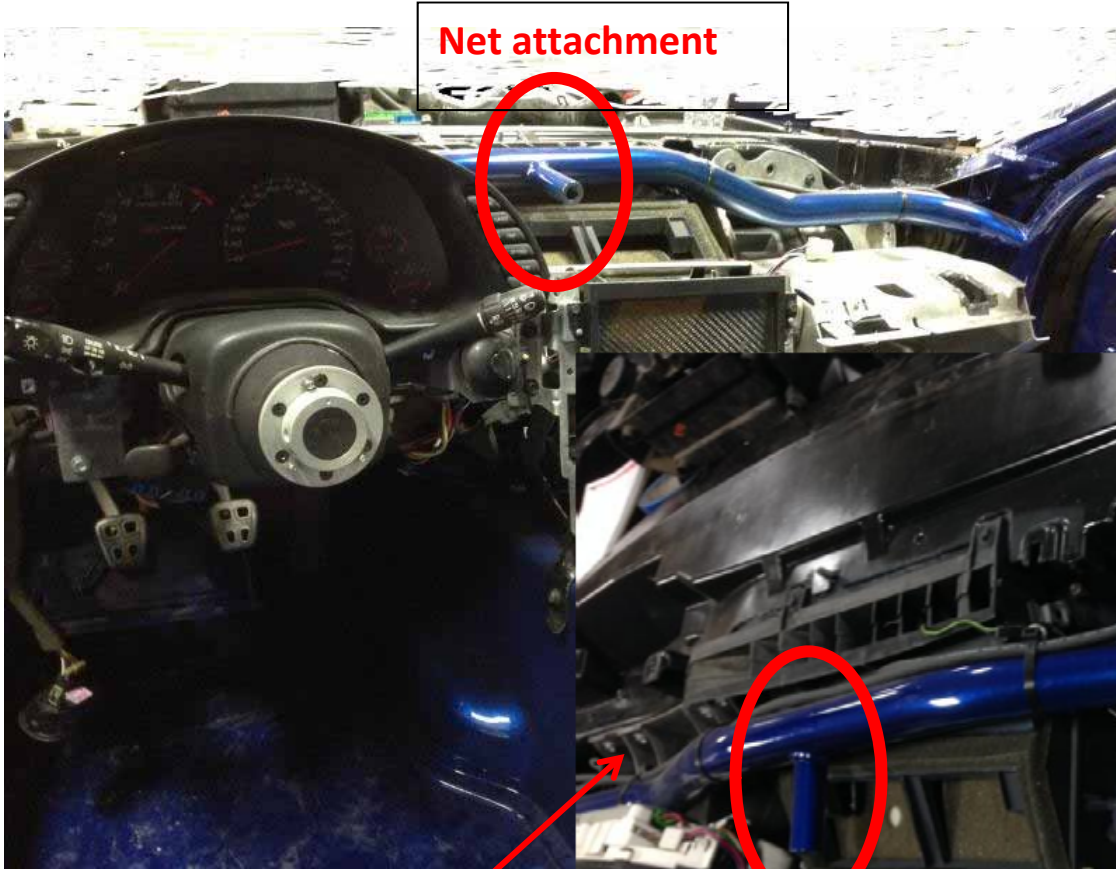

**Watch for Head-Up Display (HUD) mounts clearance**

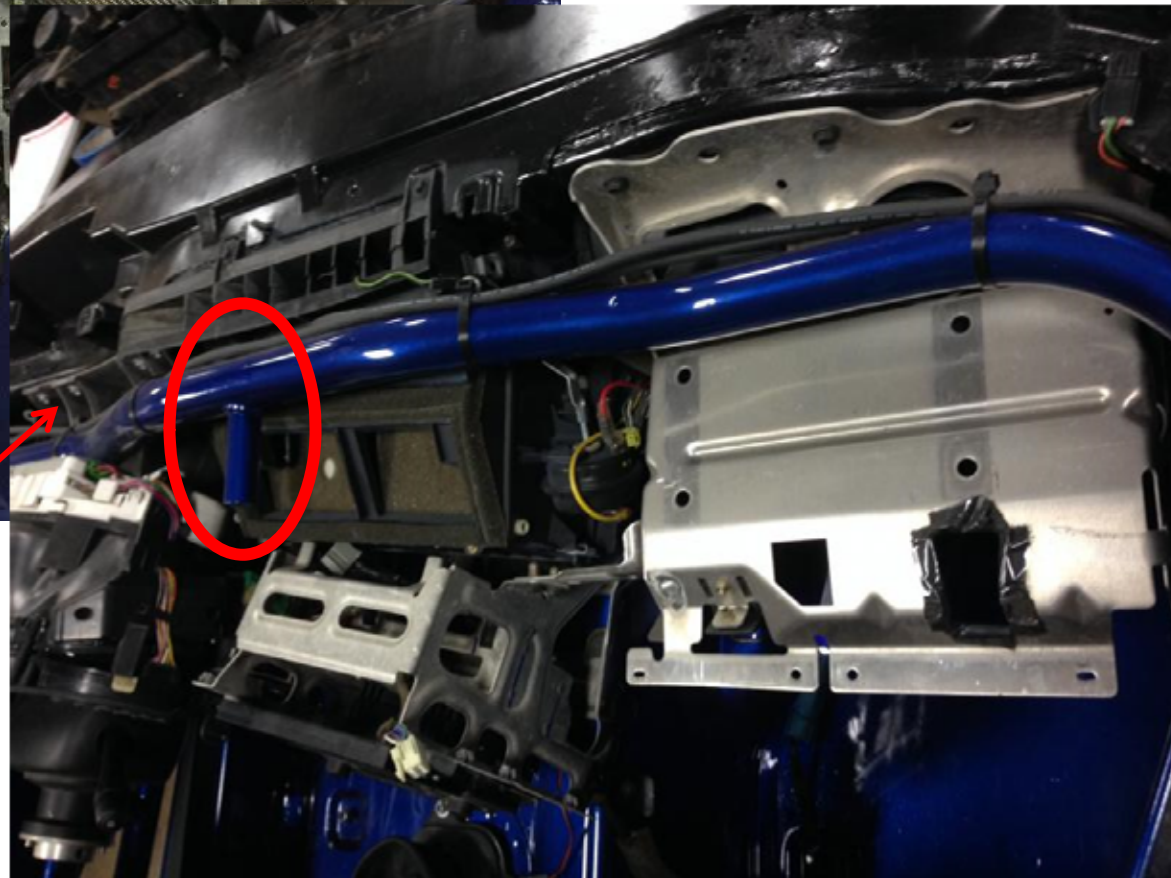



Alternate dash bar design under the steering column (not going with that option):





**Step 6: Kill switch and window net support**

