



Ground Strap and other ground point locations – 1960 Corvette

Dave Zuberer

Note the information here is based on my 1960 A.I.M. and on connections I made during rewiring of our 1960, manual transmission car. The ground strap locations also match the information provided by Lectric Limited with the Deluxe Harness set that I purchased. I cannot vouch that all the locations are 100% correct nor that I have all that there are. I have arranged the materials essentially in a “front to rear” fashion.

Voltage Regulator to Generator Ground

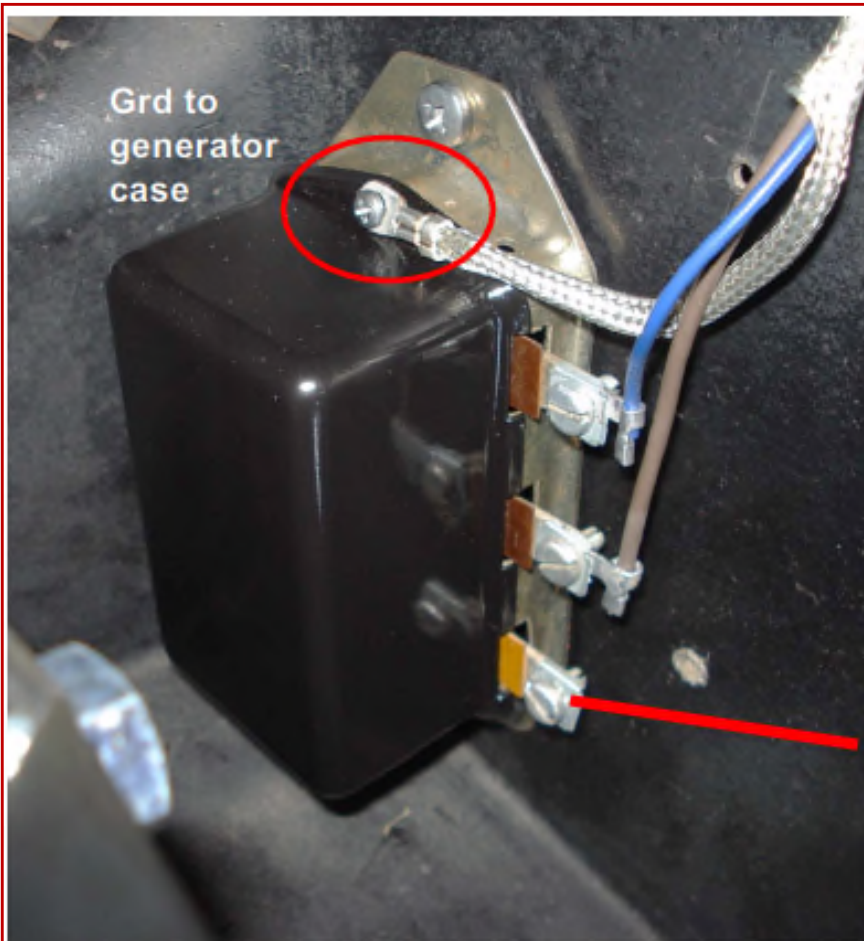

Wiring for 1960 Voltage Regulator



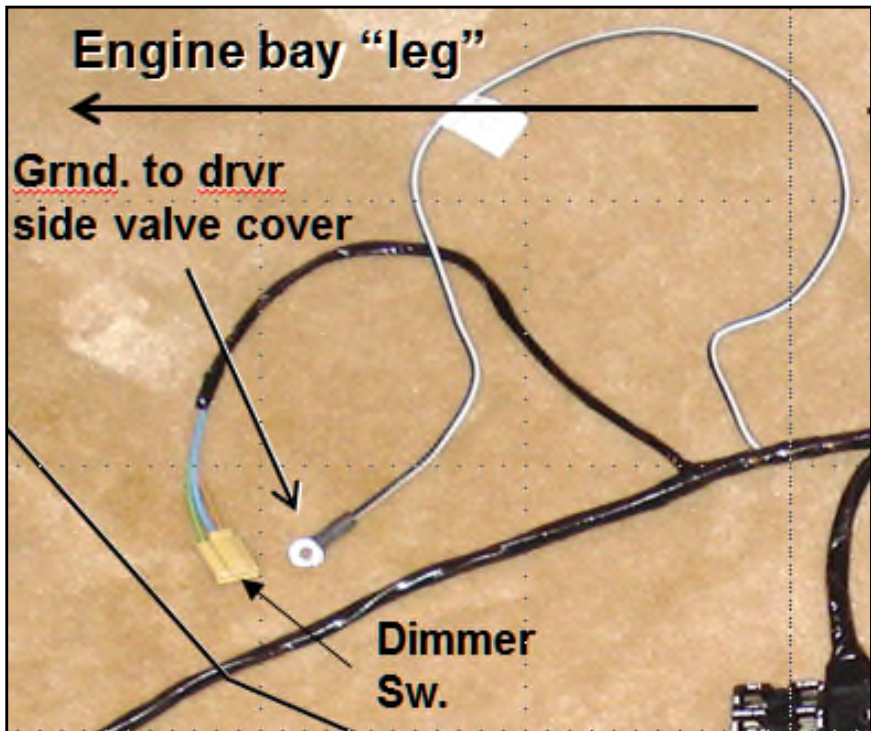

Blk/Wht ground from Dash (Main) harness through firewall to inboard rear valve cover screw on driver's side

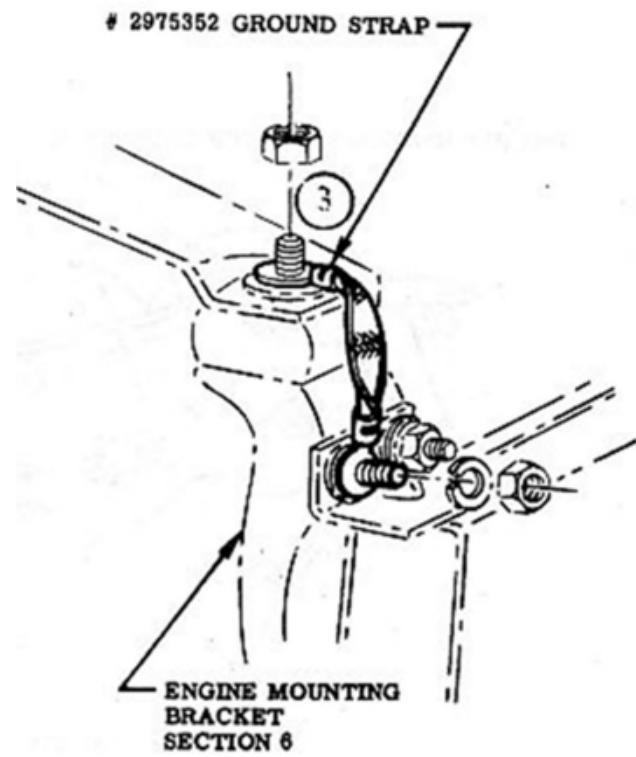

Engine Mounting Bracket Ground Straps

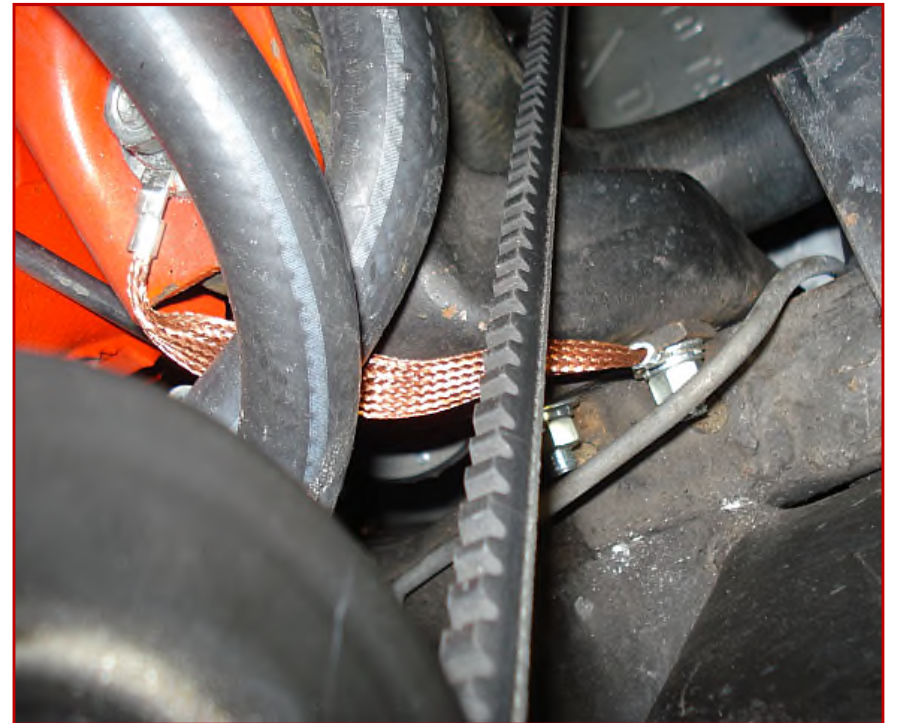
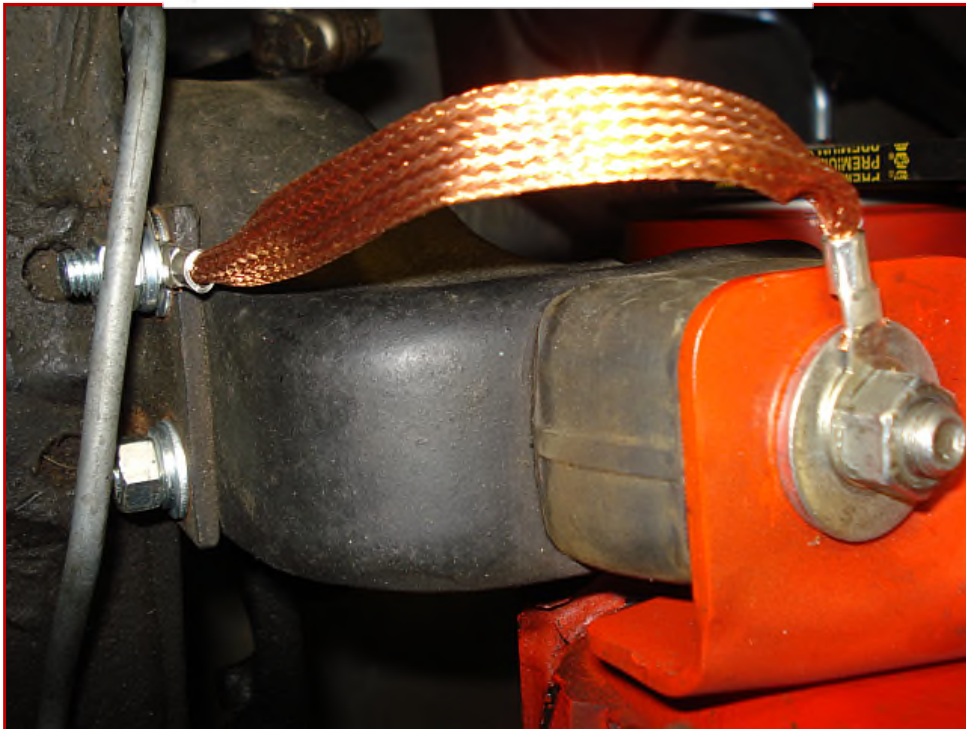

Throttle Linkage

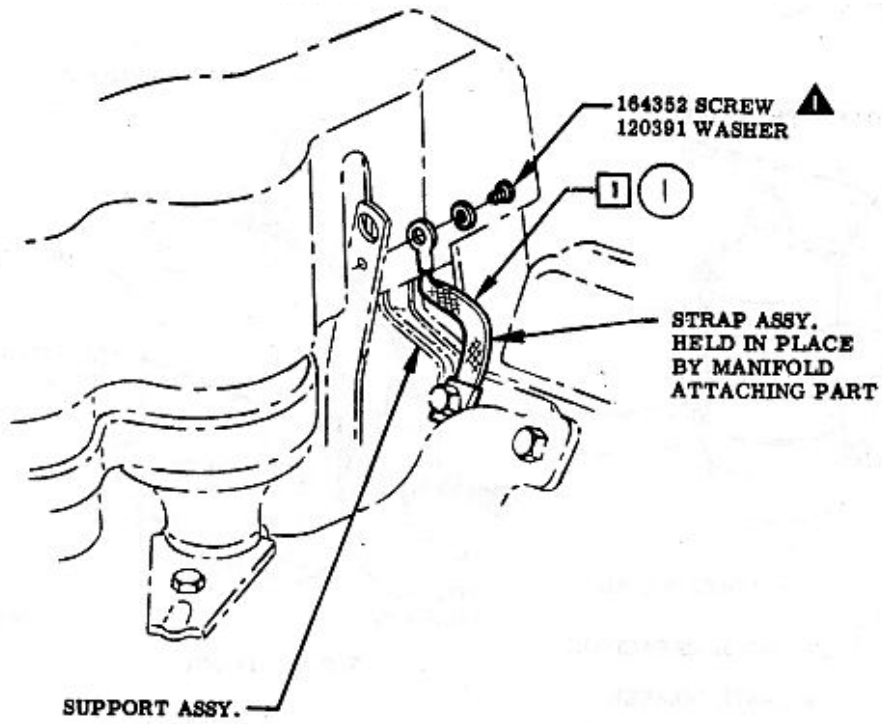

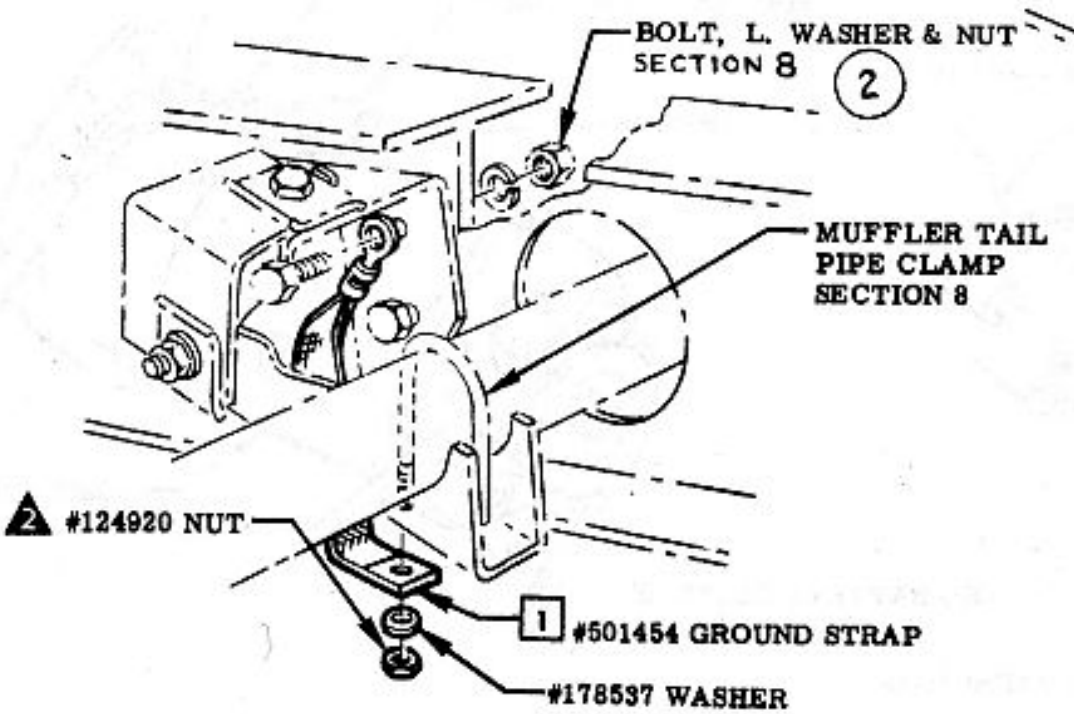

Exhaust Bracket Ground Straps

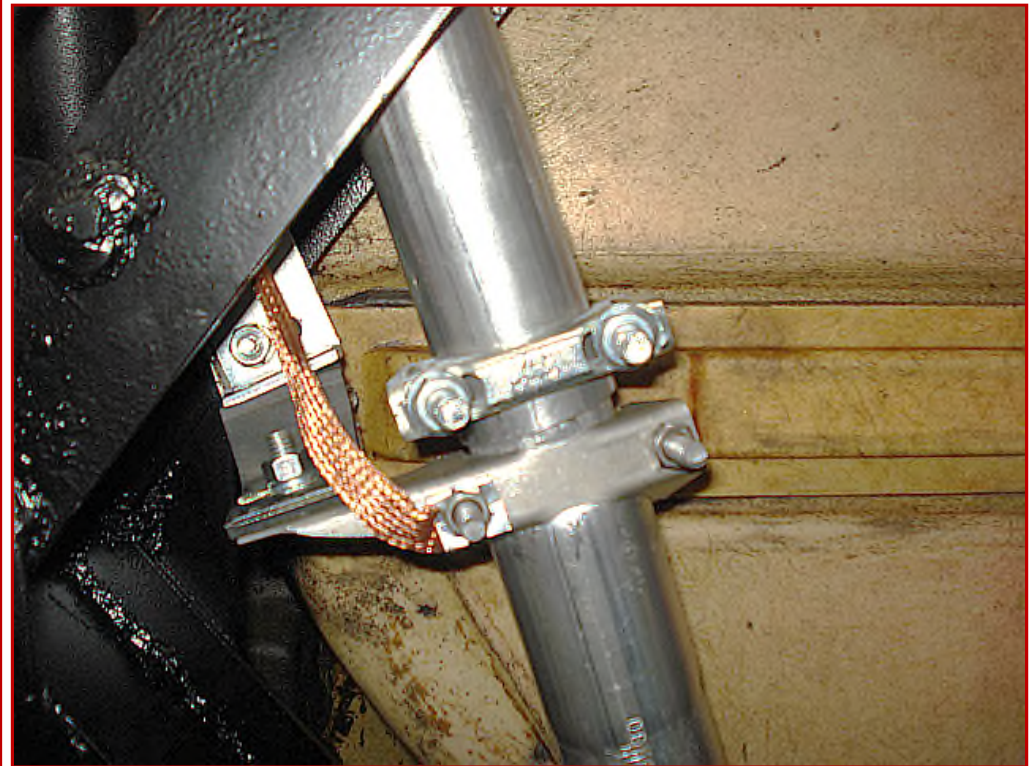
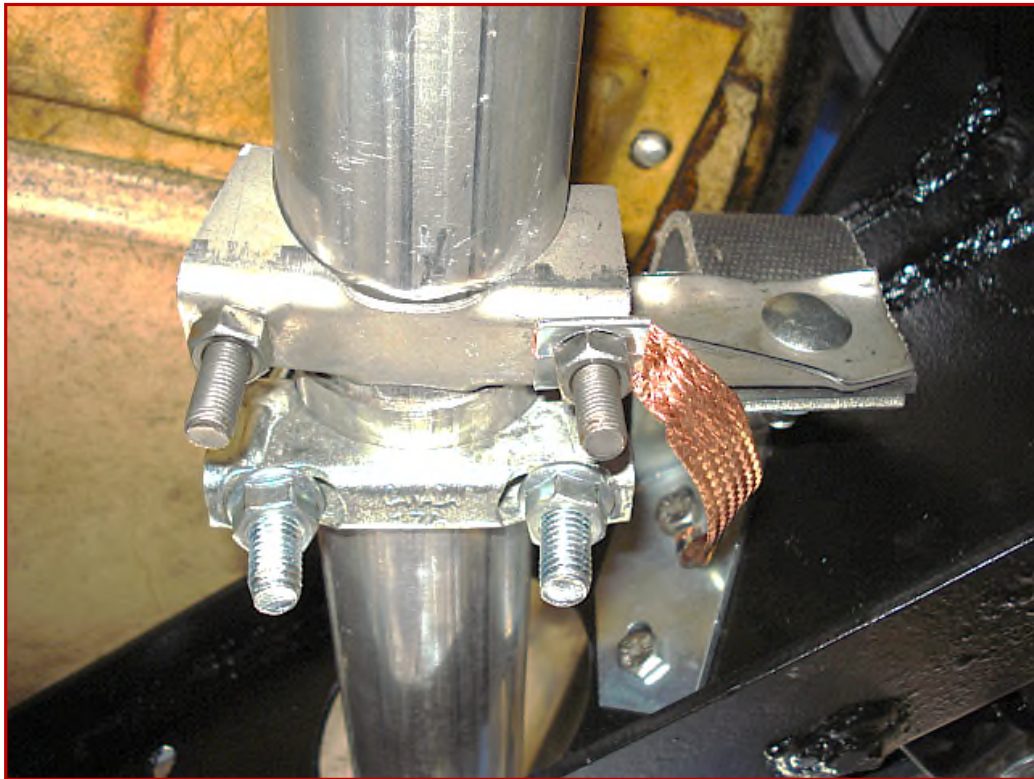

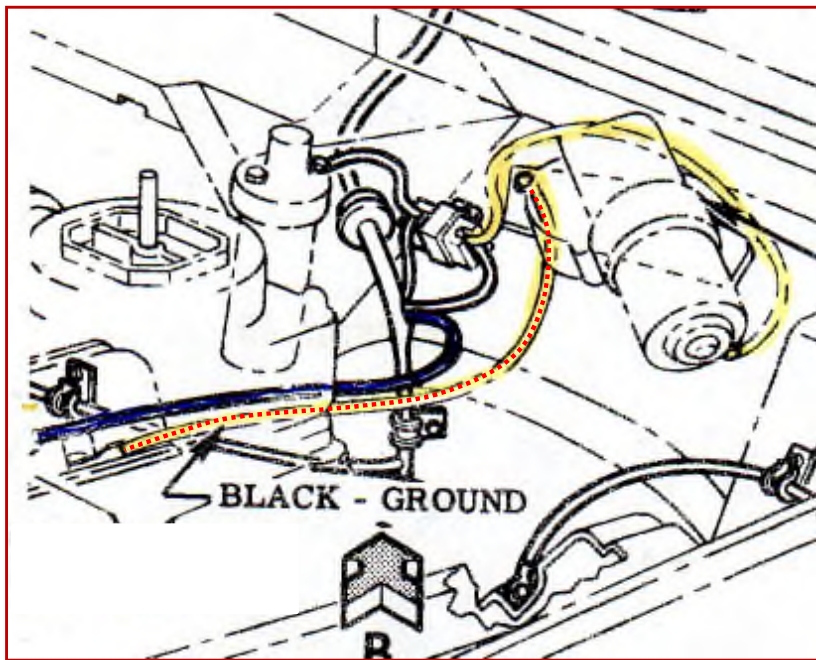

Wiper and radio grounds to psgr side valve cover

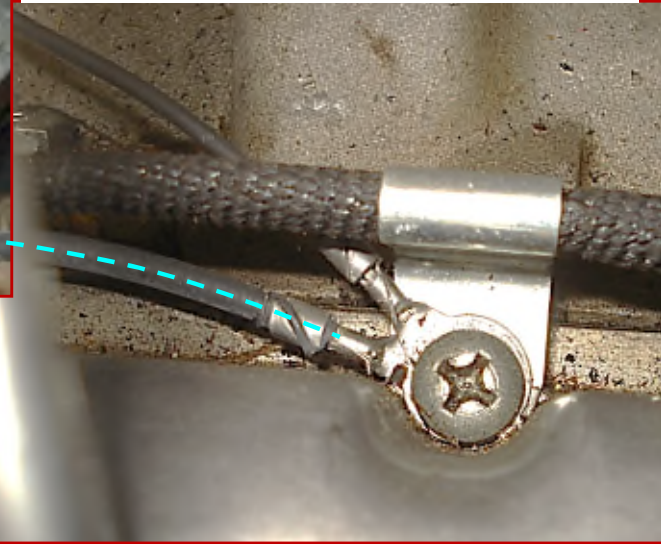

Note: this is an after-market radio

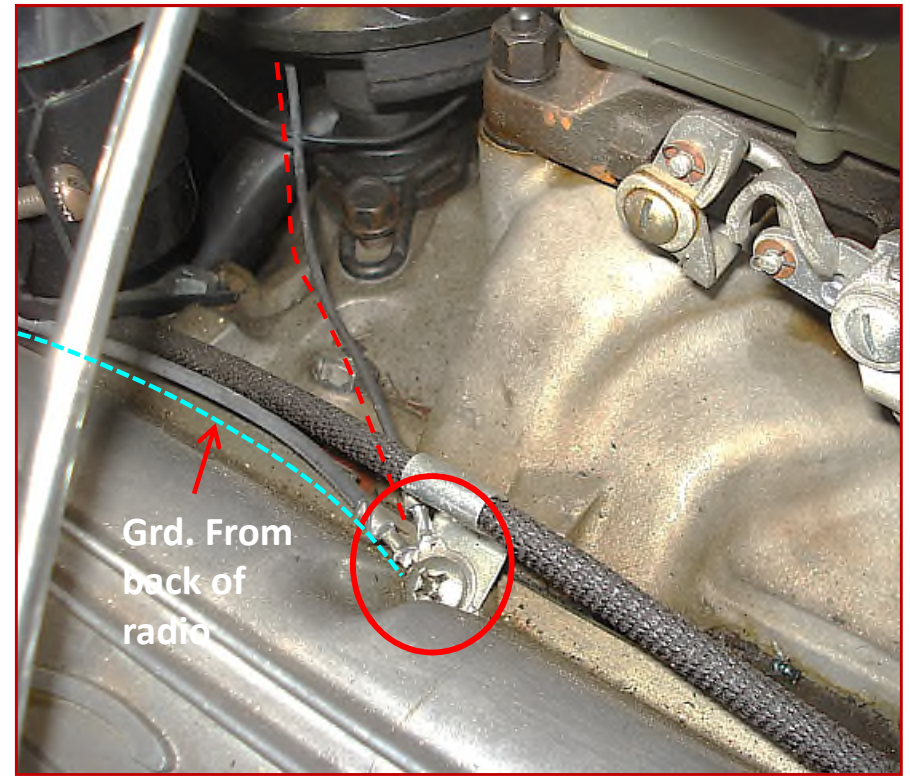
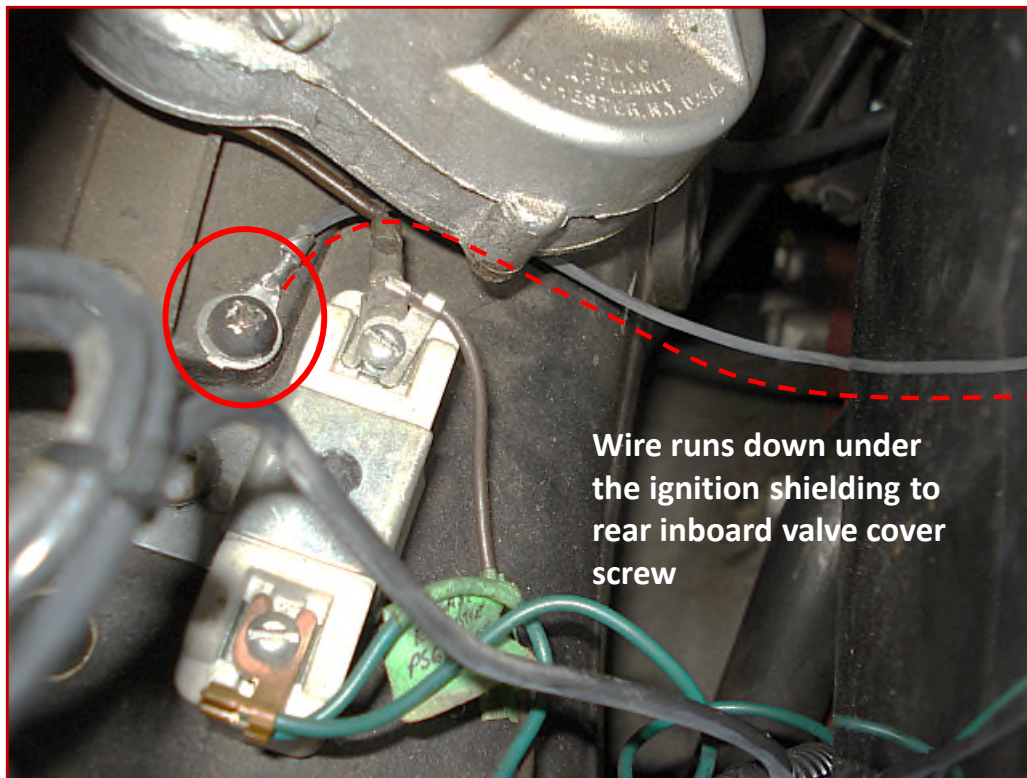

Note: all ground wires above are black. The colored lines are for tracing the routing.

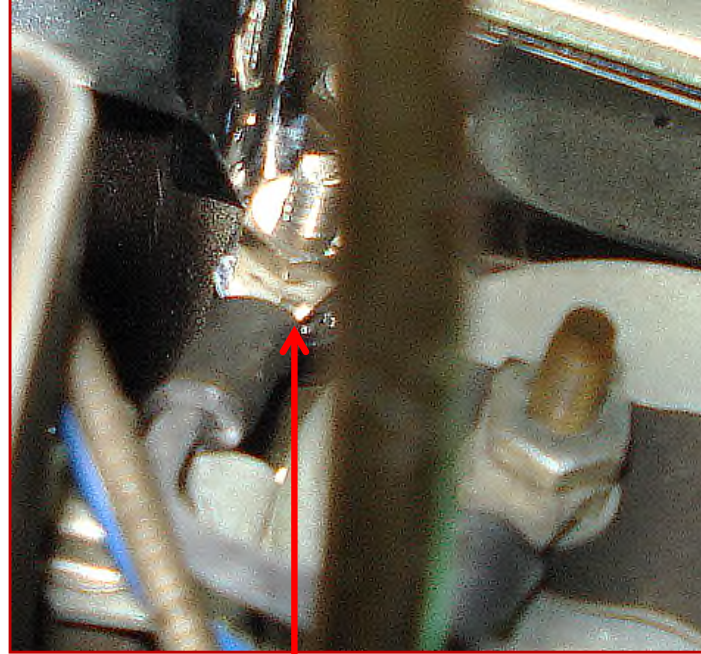

Note: I am not certain that this is the correct location for the ground to the cluster back.

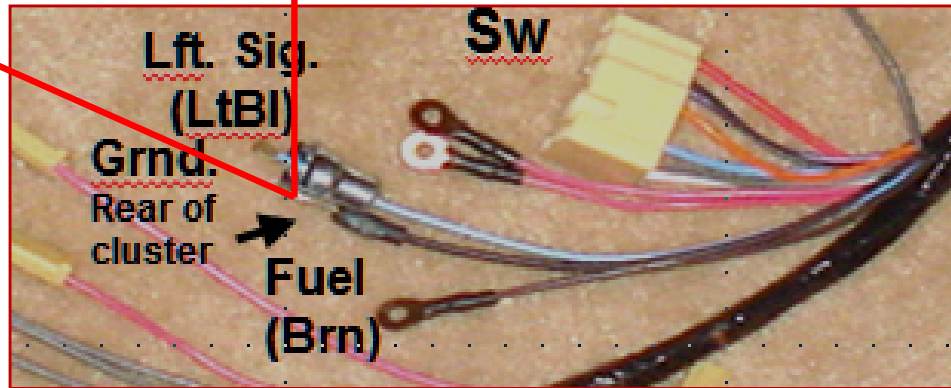
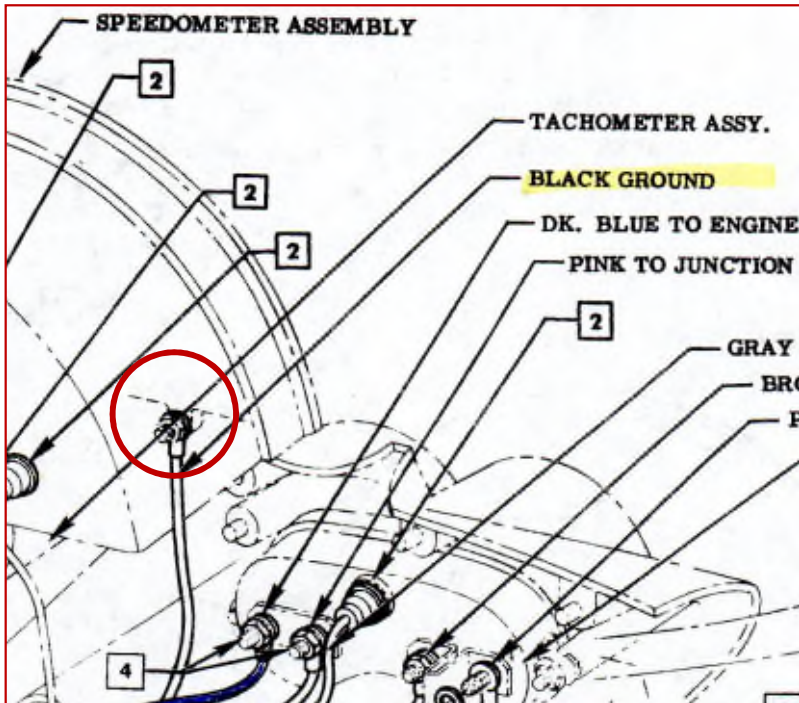

Dash (Main) Harness ground to back of instrument cluster

Ground from Dash (Main) Harness to heater name plate

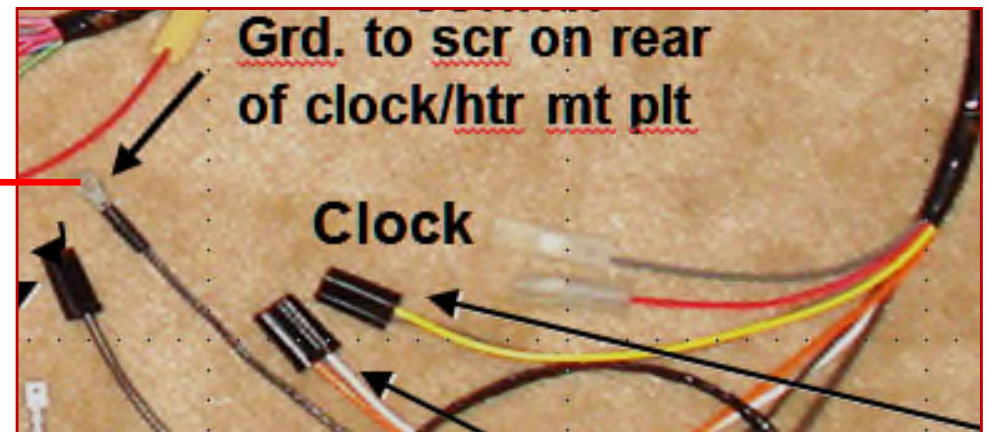
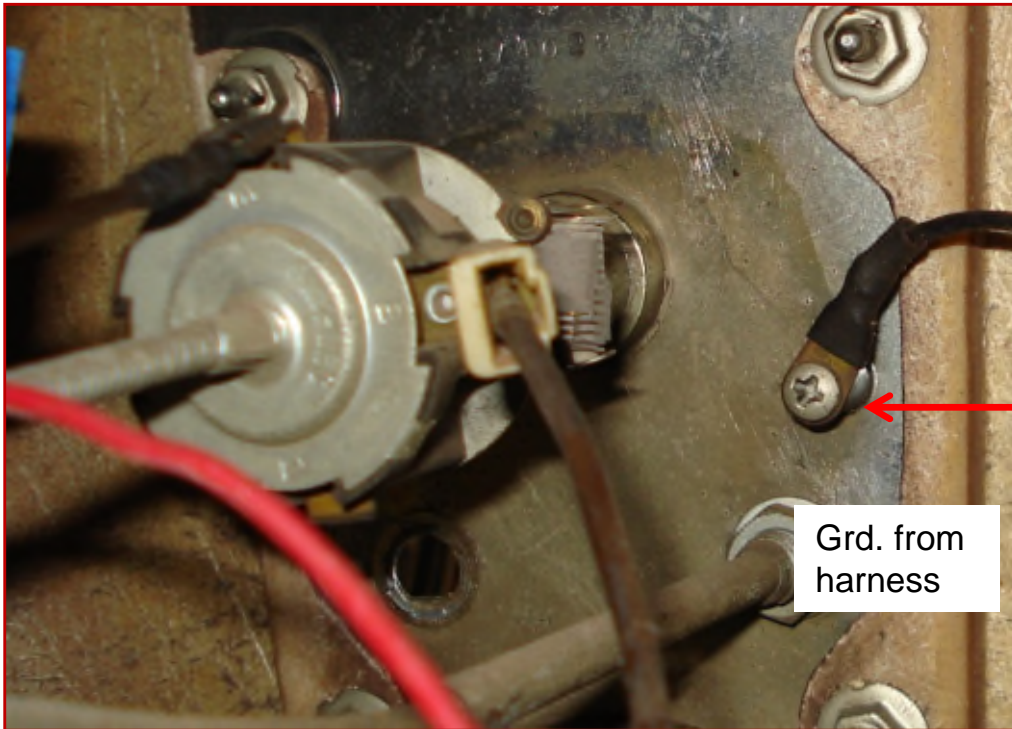
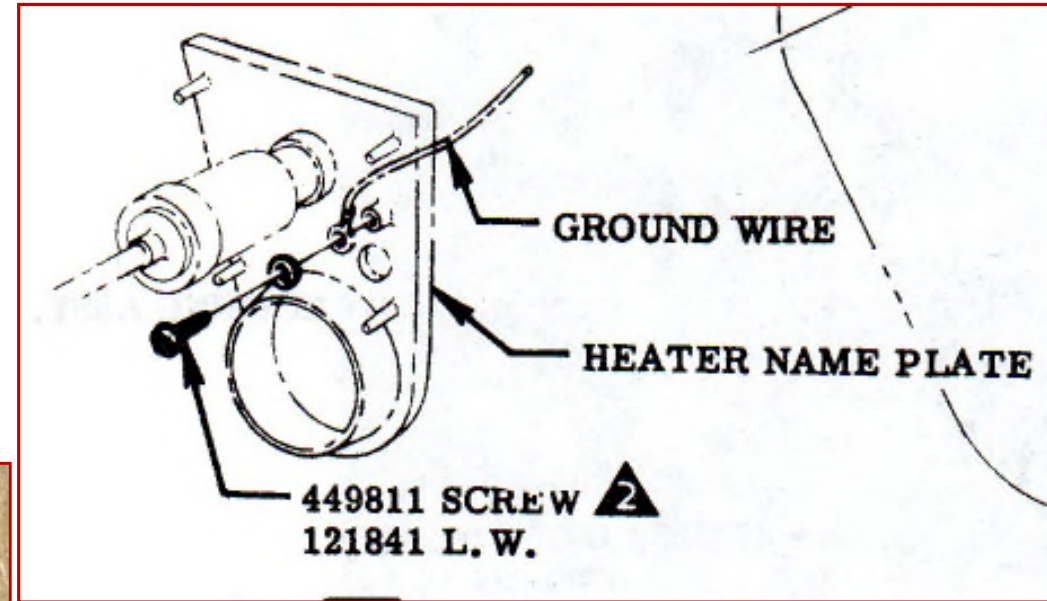

This ground wire is in what I call the "radio/clock" group

Fuel gauge sending unit ground (Blk/Wht) from harness.
"Auxiliary" ground added to eliminate dancing fuel gauge.

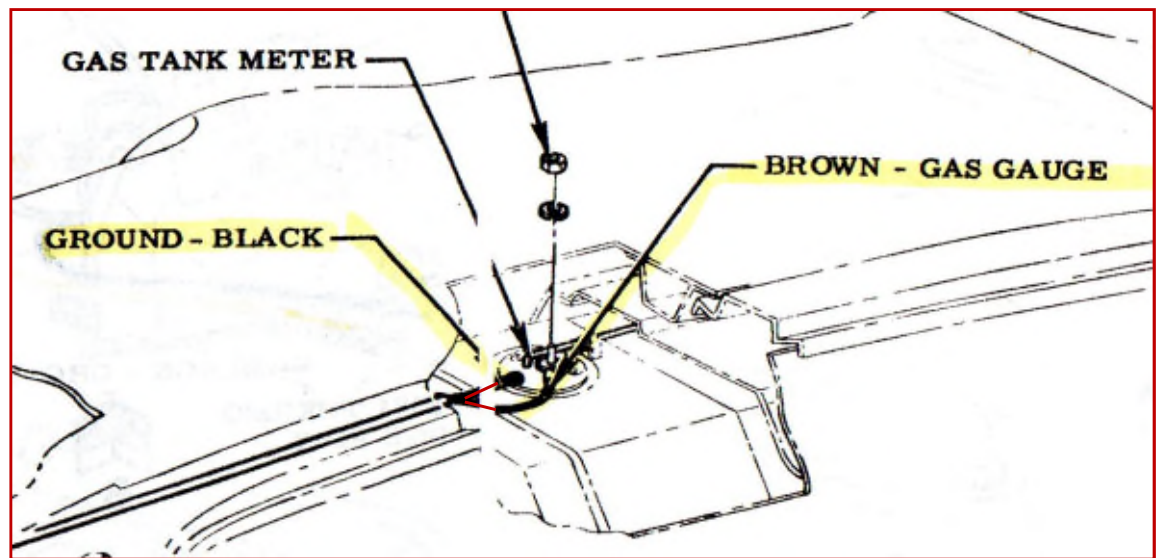

Body wiring harness –
rear lamp and license
plate

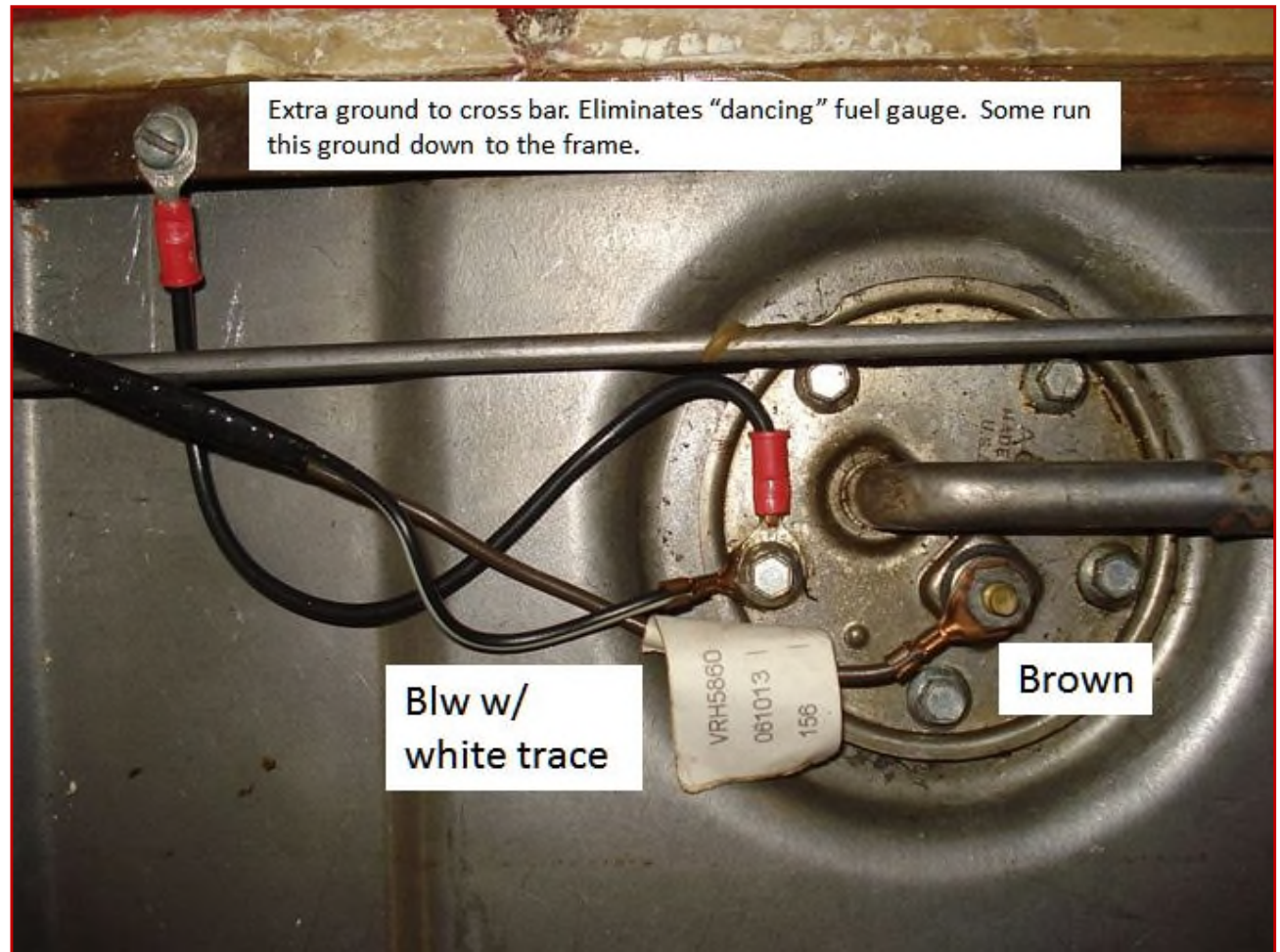

Antenna Ground Strap

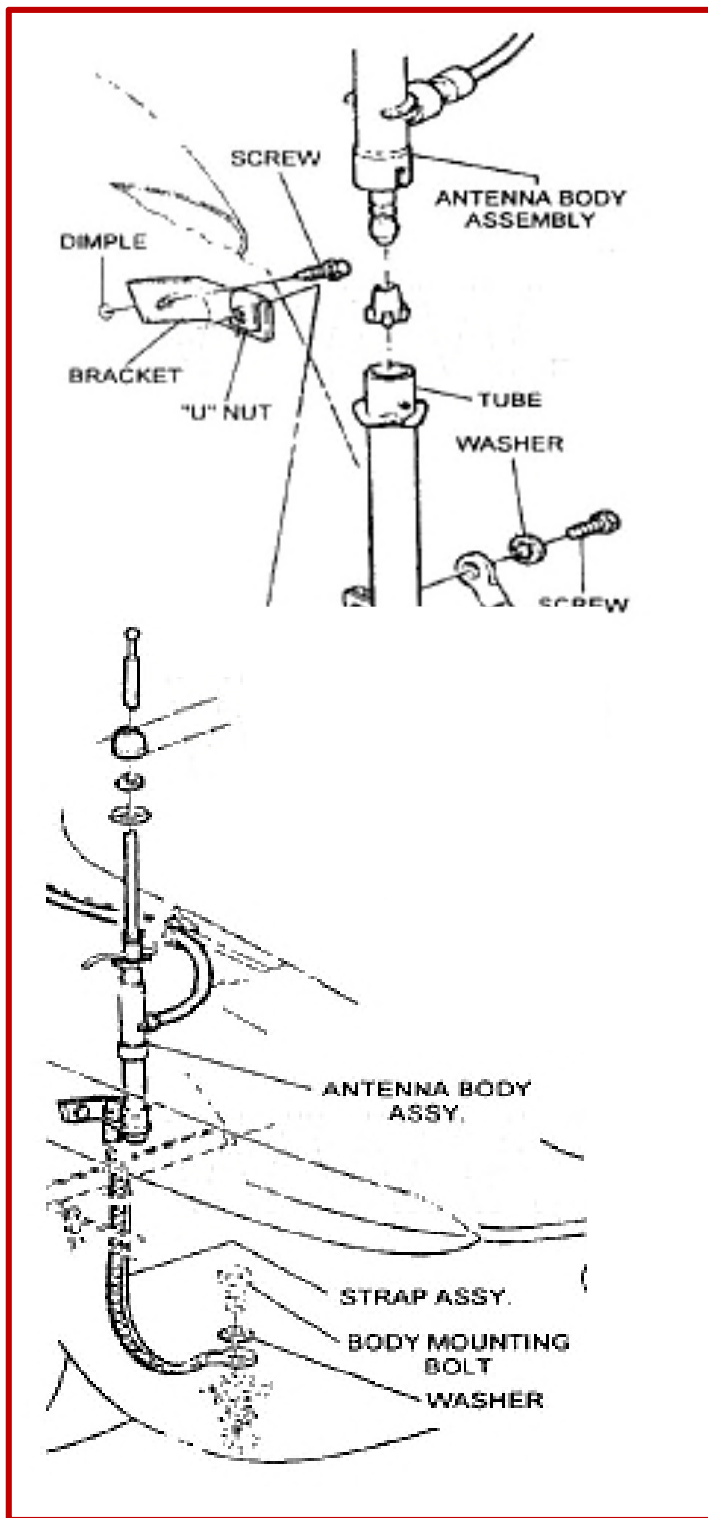

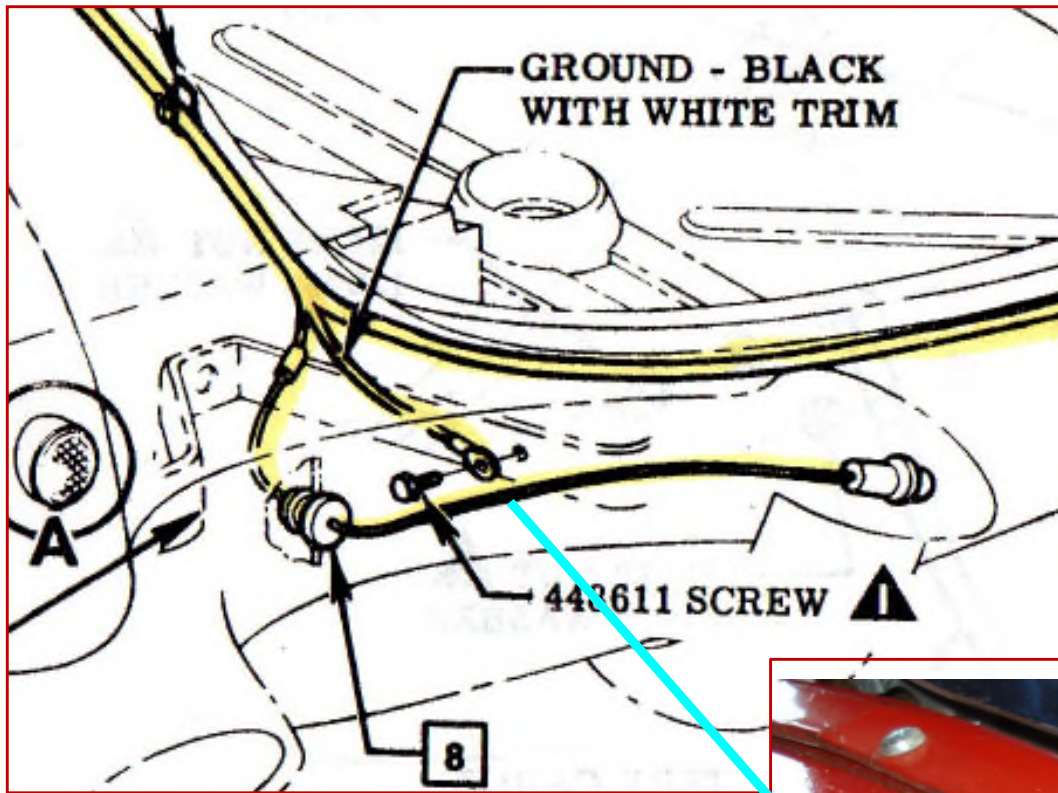

Rear body harness to driver-side bumper bracket

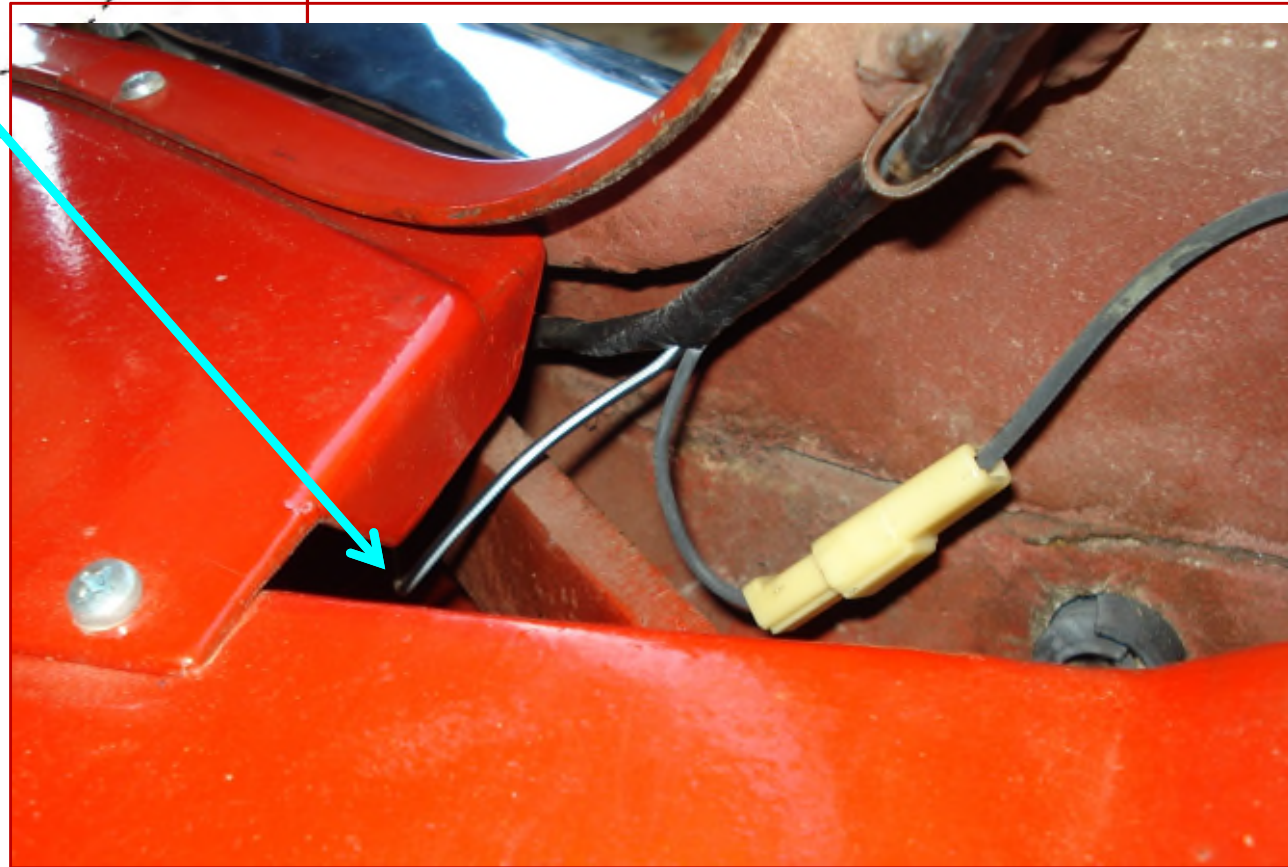

Lectric Limited 1960 Corvette Harness Sets

<http://www.lectriclimited.com/mainpage.htm>

1960 CORVETTE WIRING HARNESSSES - BASIC SET

Set Part # VS6000B1	1960 HARNESS SET - w/manual transmission reg. \$717 Discount Price \$646
VS6000B2	1960 HARNESS SET - w/automatic transmission reg. \$717 Discount Price \$646

Harness Set above includes all parts marked with an (X) below:

VMA5861	Dash (Main) Harness	X	X
VIG5861A	Engine Harness	X	.
VIG5862M	Engine Harness	.	X
VGR6062	Regulator to Generator Harness	X	X
VHX5862	Headlight Extension Harness	X	X
VRH5860	Rear Lamp Harness	X	X

Upgrade to the "Deluxe Set" below and receive more components to restore your Corvette's electrical system.

1960 CORVETTE WIRING HARNESSSES - DELUXE SET

Set Part # VS6000D1	1960 HARNESS SET - w/manual transmission reg. \$889 Discount Price \$801
VS6000D2	1960 HARNESS SET - w/automatic transmission reg. \$901 Discount Price \$811

Harness Set above includes all parts marked with an (X) below:

VLK6000	Bulb Kit (excluding headlights)	X	X
VCG5562LP	Cigarette Lighter Lamp & Shield	X	X
VDC5861	Clock Harness	X	X
VCW5862	Coil to Ballast Resistor Wire	X	X
VCL5862	Courtesy Light Harness	X	X
VMA5861	Dash (Main) Harness	X	X
VDW5570	Distributor to Coil Lead Wire	X	X
VIG5861A	Engine Harness	X	.
VIG5862M	Engine Harness	.	X
VFK5862	Fuse & Flasher Kit	X	X
VGR6062	Regulator to Generator Harness	X	X
VHX5862	Headlight Extension Harness	X	X
VHW5362	Horn Wire	X	X
VLS5860	License Plate Lamp Lead	X	X
VNS5561	Neutral Safety Switch to Transmission Relay Lead	X	.
VRH5860	Rear Lamp Harness	X	X
VGW5562WM	Wiper Motor Ground Wire	X	X
VWD5860	Wiring Diagram - laminated	X	X

BONUS! When you buy this Deluxe Set, you also receive 10% OFF any additional items on your order.