

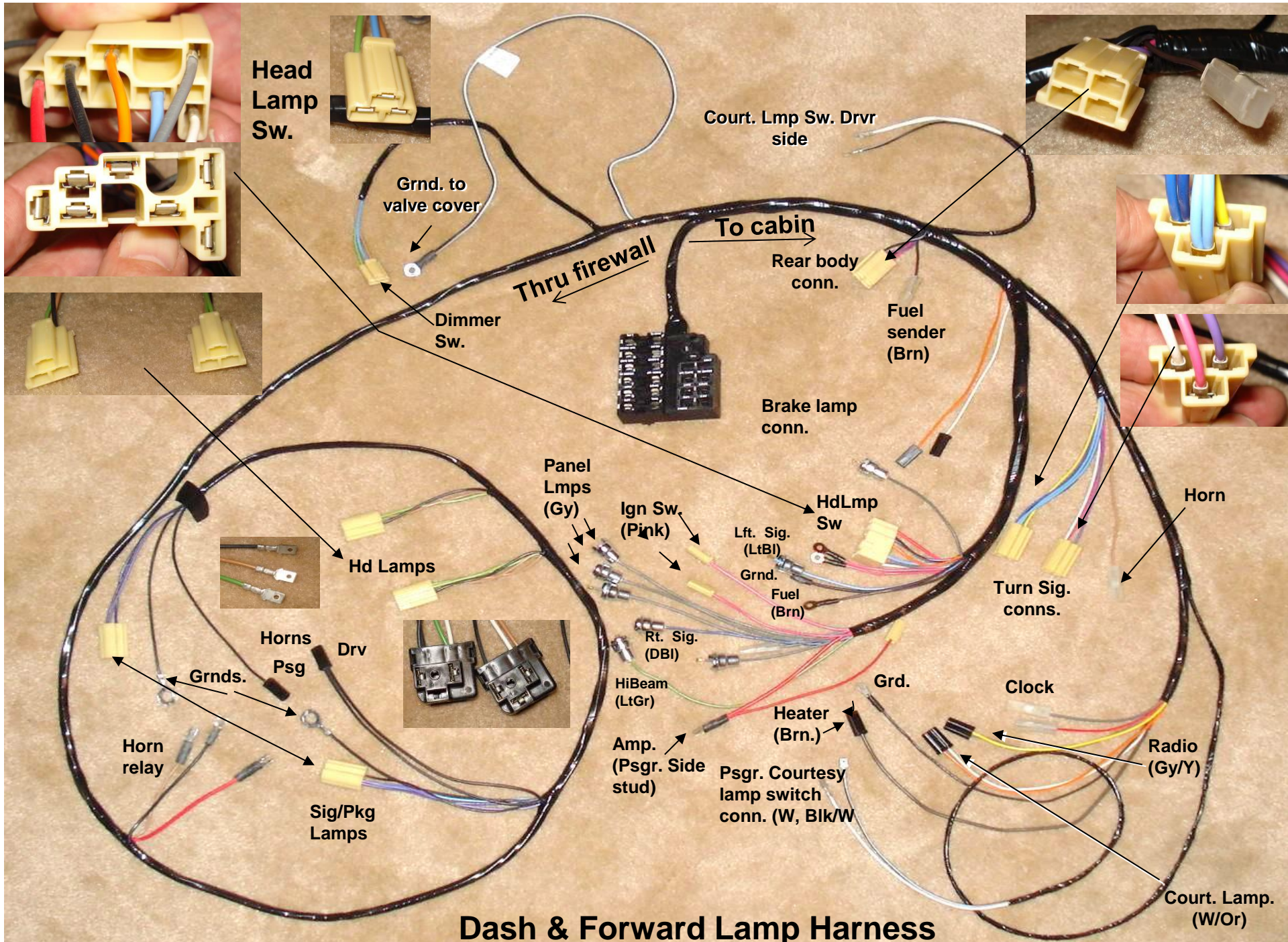

**Wiring Connections
1960 Manual Trans
Manual Windows
Manual Top**



Head Lamp Sw.

Court. Lmp Sw. Drvr side

Grnd. to valve cover

Thru firewall

To cabin

Rear body conn.

Fuel sender (Brn)

Dimmer Sw.

Brake lamp conn.

Panel Lmps (Gy)

Ign Sw. (Pink)

Lft. Sig. (LtBl)

Fuel (Brn)

HdLmp Sw

Horn

Turn Sig. conns.

Hd Lamps

Horns

Drv

Grnds.

Rt. Sig. (DBI)

HiBeam (LtGr)

Grd.

Clock

Radio (Gy/Y)

Horn relay

Psg

Sig/Pkg Lamps

Amp. (Psgr. Side stud)

Psgr. Courtesy lamp switch conn. (W, Blk/W)

Heater (Brn.)

Dash & Forward Lamp Harness

Court. Lamp. (W/Or)

Right PKG and Signal lamps

Left PKG and Signal lamps

Horn grd.

Horn grd.

Left horn conn.

Right horn conn.

Left head lamp conn.

Right head lamp conn.

Lo & Hi Beam Conn. Headlight connectors
Lo Beam Conn.

Forward Lamp Harness

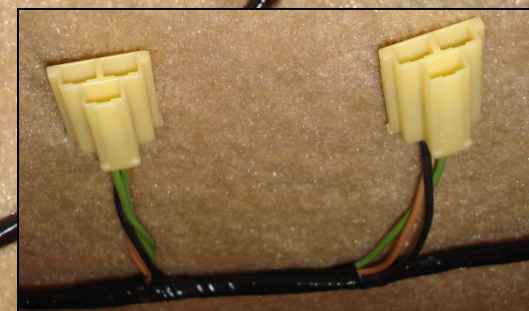
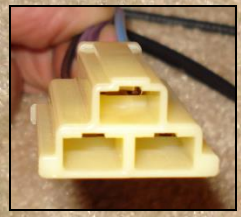

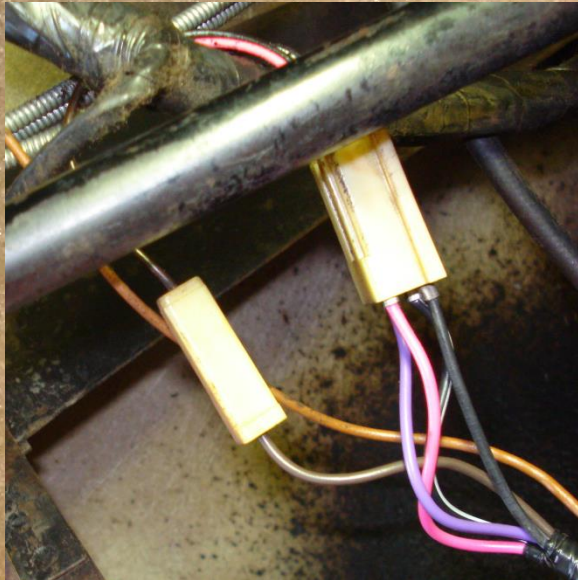

**Drvr. Courtesy
Lamp Sw. Conn.
W and Blk/W)**



**Brake Lamp Sw.
(W and Or)**



**Rear Body
Conn.**



**Fuel Sender
(Brn)
Connect to Brn from
rear body harness**

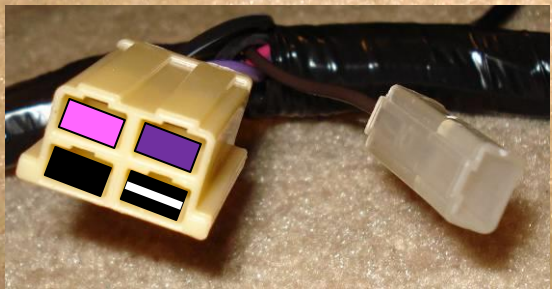

Right side of dash harness



Clock Harness

4

Clock Harn. Conn.

Radio

Courtesy Light

Ground

Heater (Brn)

Psgr. Courtesy Lamp Sw. Conn. W and Blk/W

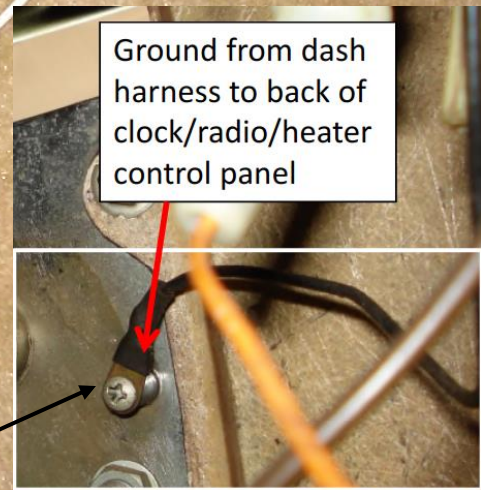

Ground from dash harness to back of clock/radio/heater control panel

Regulator to Generator Harness

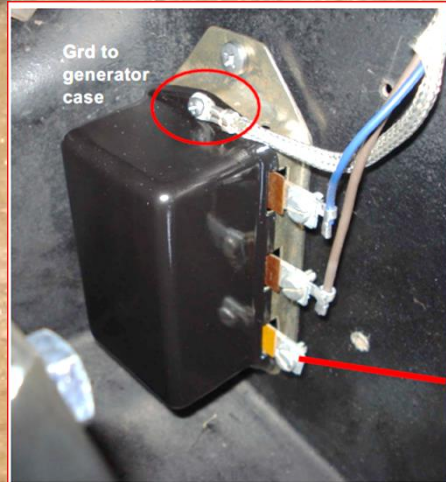

Wiring for 1960 Voltage Regulator

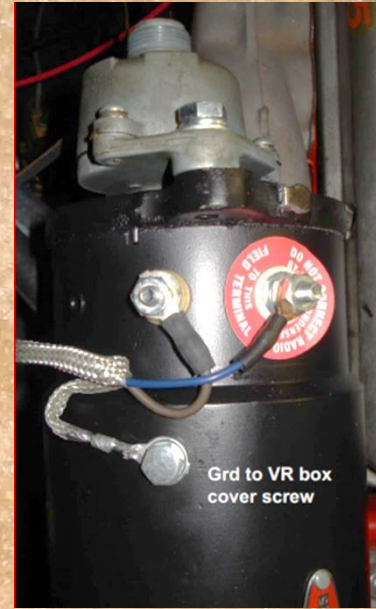

Regulator "A"
Armature term.
(Brn)

Generator "A"
Armature term.



Regulator "F"
Field term.
(DkBl)

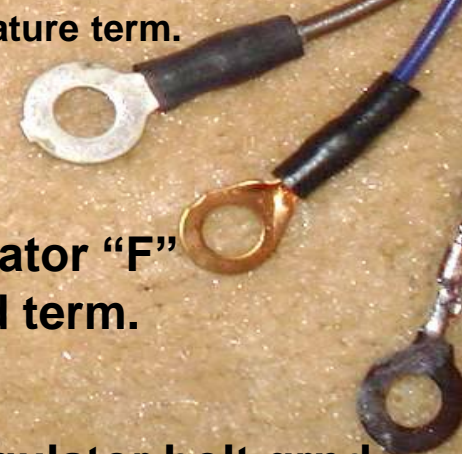

Generator "F"
Field term.

Regulator mount
screw grnd.

Regulator bolt grnd.

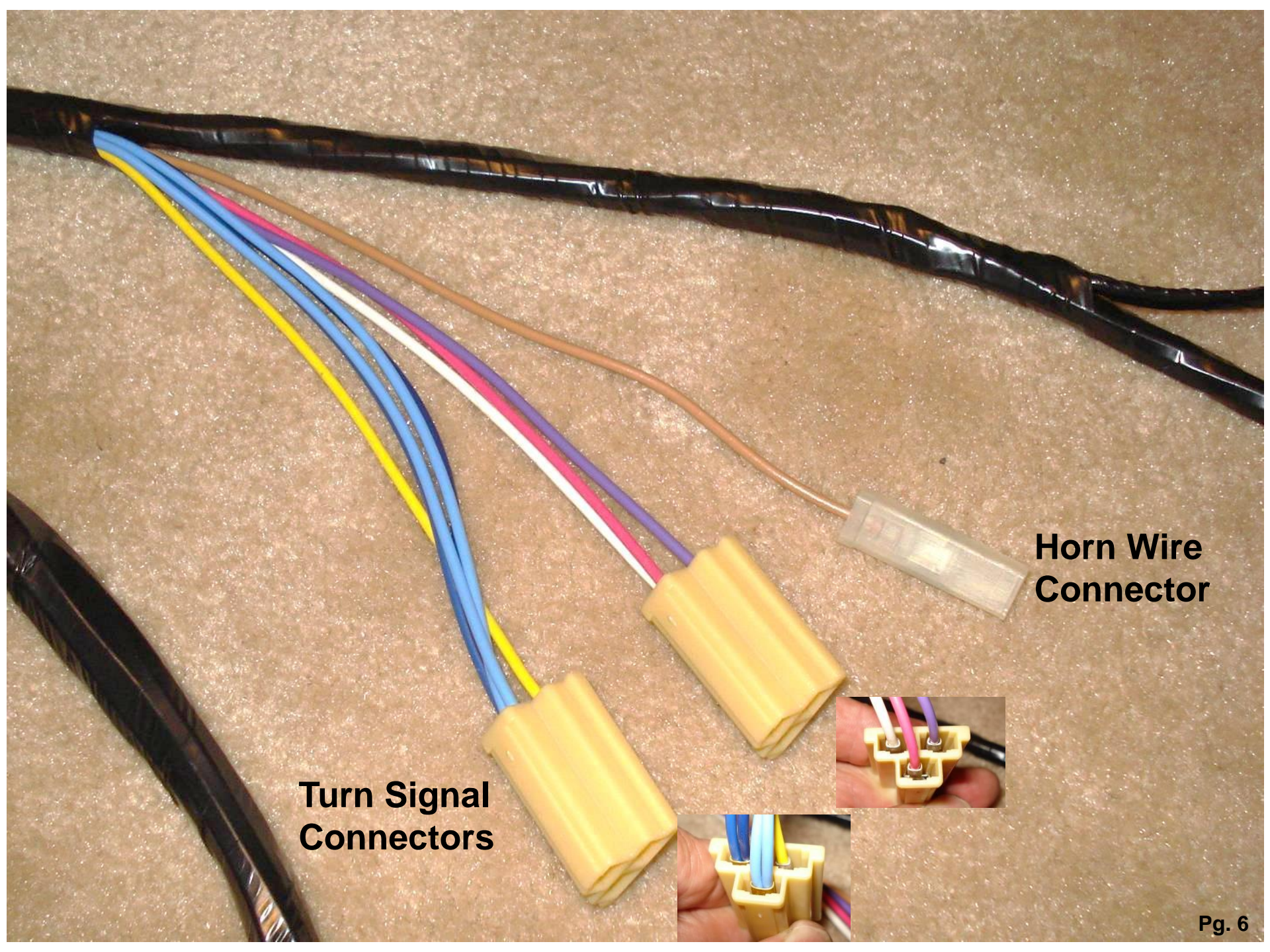

Horn Wire Connector

Turn Signal Connectors

Conn. To Cig. Lighter

Ammeter (Pmgr side (Rt) stud)

Hi Beam Indicator (LGr)

Rt. Turn indic. (DkBl)

Panel Lamps (Gray)

Lighter harness conn.

Cig. Lighter Lamp

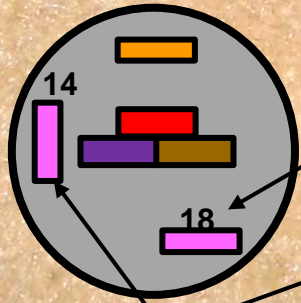

Pinks to Ign. Sw. spades

Ign. Sw.

Cig. Lighter Conn.

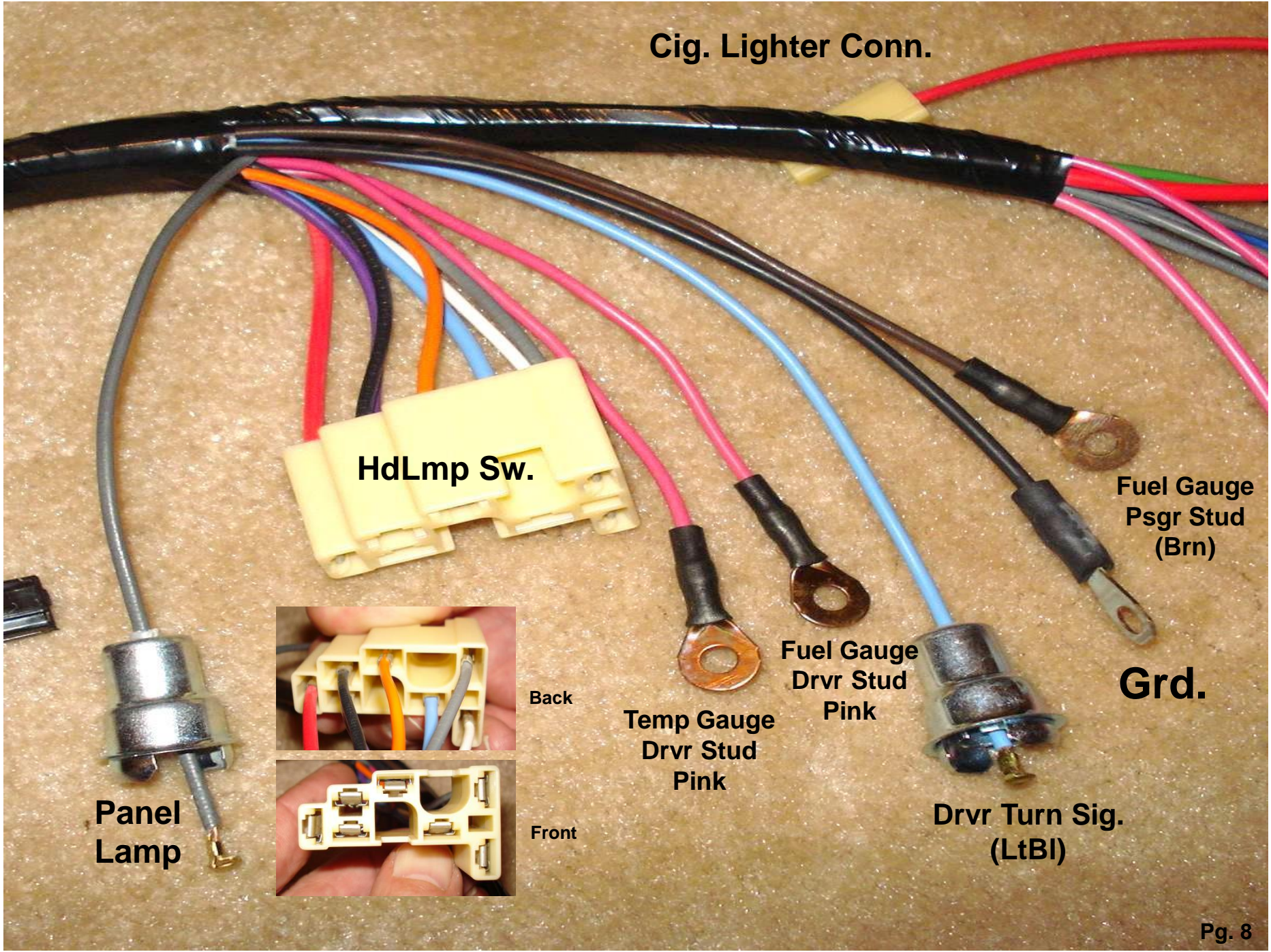

HdLmp Sw.

**Fuel Gauge
Psgr Stud
(Brn)**

Grd.

**Fuel Gauge
Drvr Stud
Pink**

**Temp Gauge
Drvr Stud
Pink**

**Drvr Turn Sig.
(LtBl)**

**Panel
Lamp**

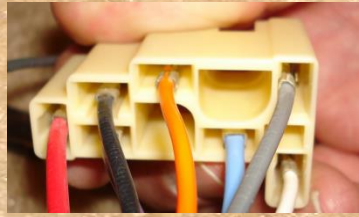

Back

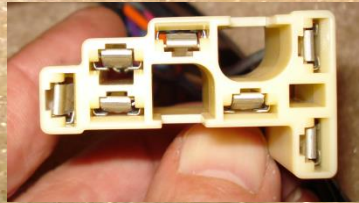

Front

Rear body/lamp harness

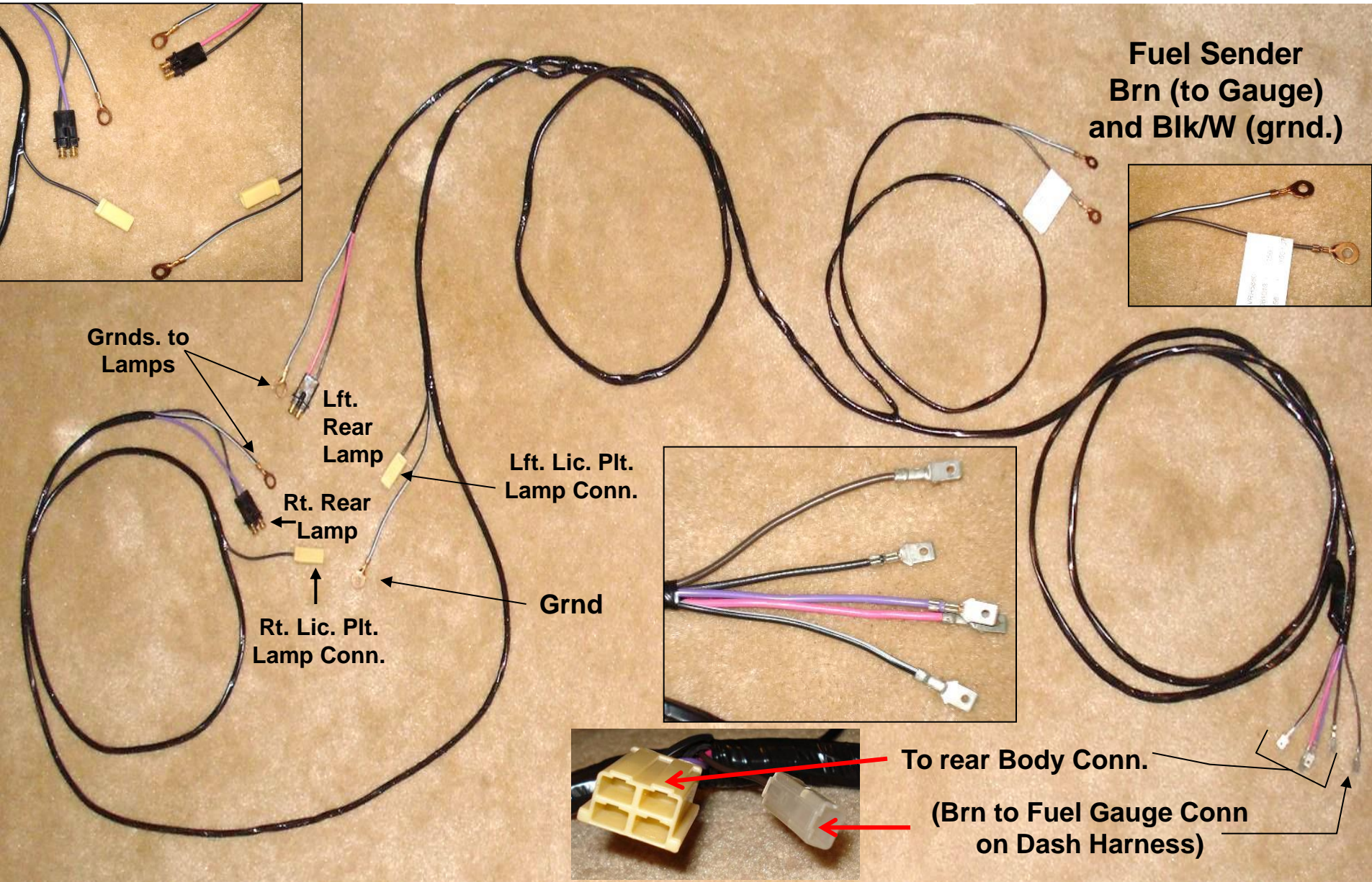

Ignition Harness

Also be aware that the factory wiring diagram has the ammeter connections shown backwards; the 12-ga. black main feed wire from the starter solenoid goes on the left side (as viewed from the driver's seat) ammeter terminal, and all the red feeds go on the right side terminal.

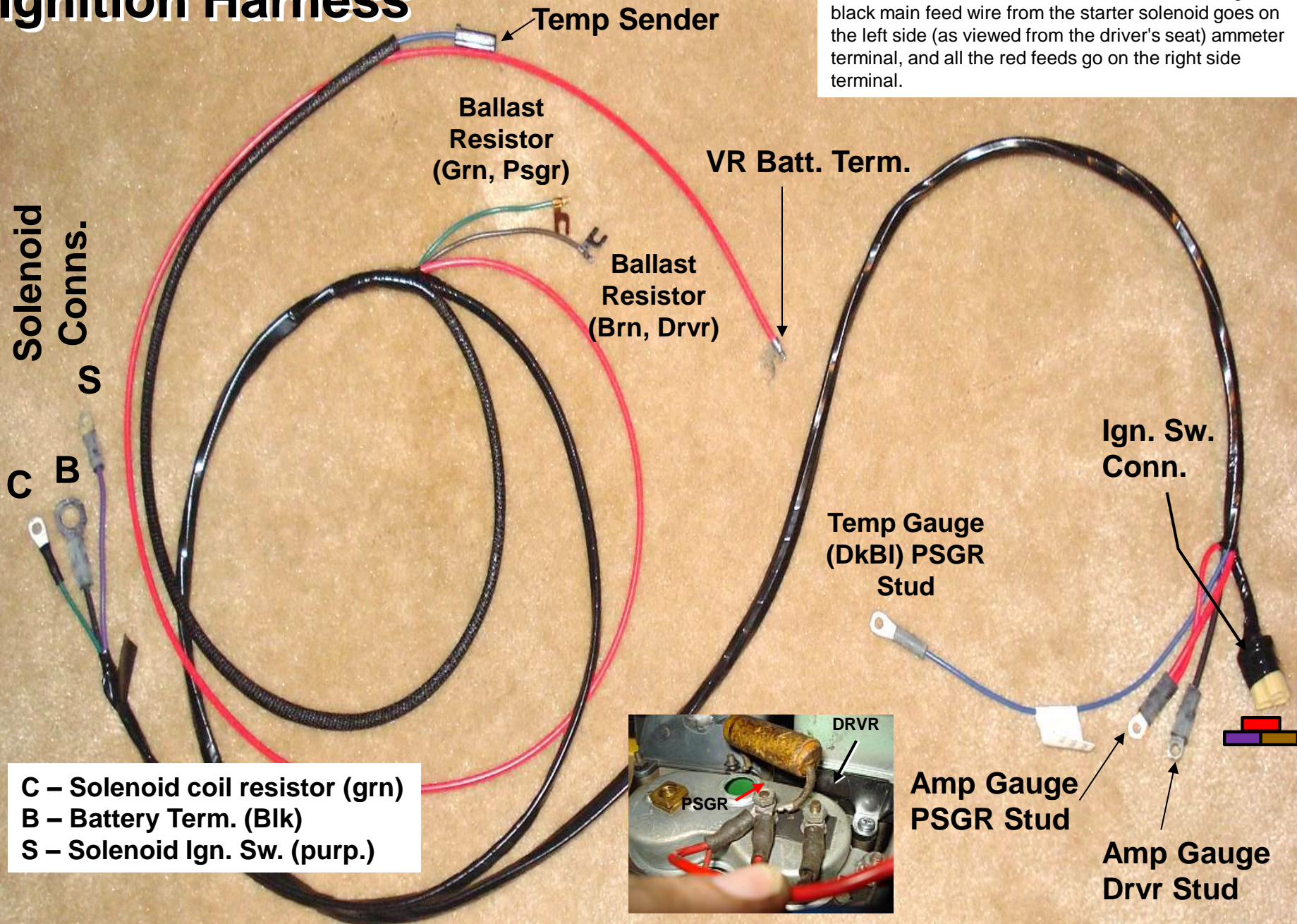

Ignition Harness Connectors

