

1972 Mechanical Numbers

Compiled by: John Woods

SUFIX	ENG/TRANS	CARB	STARTER	RADIATOR	U-HOSE	L-HOSE
CKW	350/200 QJ, 4sp	7042203	1108418	3155316/A	466 KI	669 KK
CDH	350/200 QJ, 4sp, NB2	7042903	1108418	3155316/A	466 KI	669 KK
CKX	350/200 QJ, THM	7042202	1108430/427	/C	852 JP	854 JQ
CDJ	350/200 QJ, THM, NB2	7042902	1108430/427	/C	852 JP	854 JQ
CKY	350/255 HY, 4sp	9263/6239	1108418	/C	852 JP	854 JQ
CKZ	350/255 Hy, 4sp, ZR1	9263/6239	1108381*	3007436/A	761 ST	854 JQ
CSR	454/270 QJ, 4sp	7042217	1108400	/C	433 JY	868 UP
CSS	454/270 QJ, THM	7042216	1108429	/C		(928 TW & 929 TK WITH C60)

KEYS
SQ = C
RD = D

SHOCKS
FT RR
STD PE PY
F41 PF PR

CARB DATES
ROC DDDY
CAR M Y
HOL Y M W

* w/M22

LT1 w/M22 uses 436

HP	HEADS	INTAKE	LH EXH	RH EXH	DIST	VAC	COIL	STOVE	E.LBL.	A/C	W/P	ALT BC*	BLOCK
200	3973487X	6263751	3932461	3989036*	1112050	437	270	AN	007 LJ	002	399*	950 RF	010/014
255	3973487X	3959594	3932461	3932461	1112101	437	270	BX	012 LP	002	389	950 RF	010/014
270	3999241	6263753	3969869	3880828	1112051	436	287	CM	020 LZ	797	100	543 RG	289

* later use 461, 200 has no AIR

>May 813 * w/c60 544 RH

LTR	CAST	STAMP	BODY	FINAL	JULIAN
A	Jan	Jan	Aug	01344	031
B	Feb	Feb	Sep	03697	060
C	Mar	Mar	Oct	06050	091
D	Apr	Apr	Nov	08406	121
E	May	May	Dec	10310	152
F	Jun	Jun	Jan	12661	182
G	Jul	Jul	Feb	15020	213
H	Aug	Aug	Mar	17613	244
I	Sep	----	Apr	19993	274
J	Oct	Sep	May	22611	305
K	Nov	Oct	Jun	25226	335
L	Dec	Nov	Jul	27004	366
M	----	Dec			

VIN: 1Z67K2S527004 conv.
37 coup
K=base, L=LT1, W=454

A.I.R. SYSTEM

DIVT.	CK V	PULLEY	
200 NB2/255	199 GL	992	234
270	190 JA	992	522
HOSES:	LH 476 RC	RH 740 JA	

FAN: Early W, Late B; both square
DATE: A JJJ Y S M (assbly, date, shift, mod)

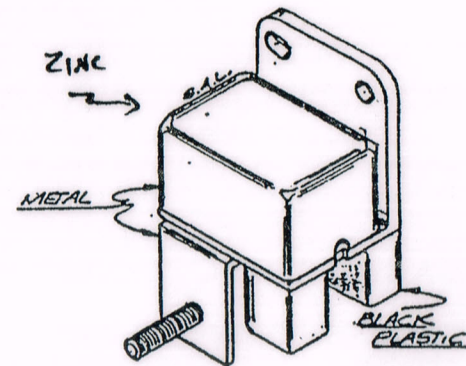

M D D Y S