

CHEVROLET *POWER*

5th EDITION

- technical data
- specifications
- special parts

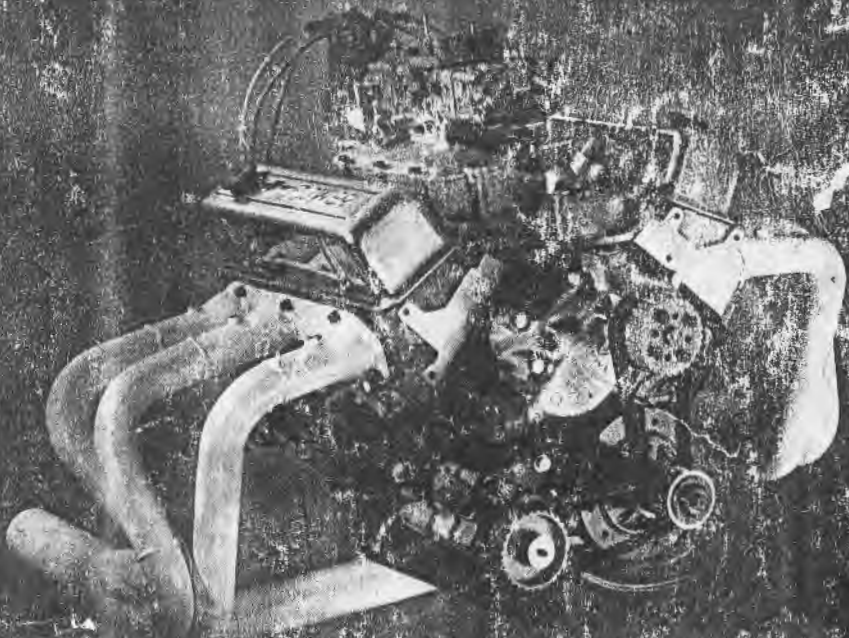

Parts

PUB. #MO12

GENERAL MOTORS CORPORATION



C
O
R
V
E
T
T
E

I
S

CORVETTE SECTION

	Page
Introduction: Corvette Chassis Preparation	6-1
Frame Preparation	6-1
Front Suspension	6-4
Rear Suspension	6-6
Clutch and Transmission Preparation:	
a. Clutch	6-7
b. Transmission	6-9
Rear Axle and Differential	6-11
Suggested Chevrolet Service Parts:	
1. Differential Carrier Assembly	6-13
2. Ring and Pinion Gear Set	6-15
3. Differential Case	6-15
4. Bearing Asm.	6-15
5. Misc. Service Parts	6-15
6. Recommended Bolt Torques	6-15
Brake System:	
1. Components	6-15
2. Hydraulics	6-15
3. Ventilation	6-16
Corvette Chassis Modifications	6-16

Corvette Section

Figure	Description	Page
1	Desired corner braces providing increased lateral stiffness	6-1
2	Frame showing the full length air weld	6-1
3	Required frame reinforcement near the steering gear asm.	6-2
4	Installation of automatic transmission crossmember	6-3
5	Typical roll cage welded to the frame asm.	6-3
6	Weld gussets to crossmember and lower control arm brackets	6-3
7	Area of frame rail requiring shock absorber clearance	6-4
8	Replacement of rubber parts with solid plates and bushings	6-4
9	Weld tapping plate to inside of frame rail for stabilizer bar bearing attachments	6-5
10	Reinforce welds on stabilizer bar bracket and remove the upper/lower bumpers	6-5
11	Proper front and rear vehicle trim heights	6-6
12	Reworking rear suspensions control arm	6-7
13	Rear suspension strut rod replacements	6-7
14	Rear stabilizer bar installation	6-8
15	Lapping the clutch disc on the clutch gear to remove any burrs	6-8
16	Illustrated transmission identifying the circumferential grooves on input shaft	6-9
17	Exploded view of a Muncie Four Speed transmission	6-10
18	Polishing front and rear surfaces of counter gear	6-11
19	Cone and blocker ring referenced in Step four	6-11
20	Blocker ring comparison showing wiping grooves or slot modifications	6-11
21	Blocker ring with small "B" imprinted on ring at small end of cone	6-11
22	Comparison of a stock washer and a washer with the desired 90° hand	6-12
23	Counter gear rear thrust surface	6-12
24	Reworked 1st gear, special thrust washer and needle bearing	6-12
25	Exploded view of the Corvette transmission	6-13
26	Exploded view of the Corvette rear axle carrier assembly	6-14
27	Exploded view of Corvette differential carrier (DANA)	6-15
28	Heavy duty suspension instruction sheet for the Corvette	6-18
29	Adjustment procedure for brake proportioning valve	6-19
30	Exploded view of typical Corvette front suspension	6-20-21
31	Exploded view of typical Corvette rear suspension	6-22-23
32	Steering column & steering linkage (typical)	6-24-25
33	1984 "Y" rack and pinion steering - power	6-26
34	1984 "Y" front suspension	6-28
35	1984 "Y" rear suspension	6-30
36	1980-82 "Y" rear suspension	6-32

CORVETTE CHASSIS PREPARATION

The following specifications and modifications procedures are intended to assist an individual preparing a Corvette chassis for road course competition such as the I.M.S.A. GT series or S.C.C.A. Trans-Am series.

A thorough knowledge of the current competition rules is essential since the sanctioning organizations rules and interpretation of existing rules frequently change.

These suggested modifications such as frame reinforcements or rewelded seams are only required for off-highway competition activities where abnormal stresses are encountered and for a roll over safety cage installation. It does not imply any inherent structural deficiencies exist in the production components for normal highway usage.

Frame Preparation

The frame should be removed from the vehicle for thorough cleaning (sand blast preferably) and preparation. Use a new 1969 or later Corvette frame or a good solid non-rusted 1969 or later used frame. A new frame is recommended to minimize the possibility of weakening due to any corrosion encountered during service life. The 1969 and later frames incorporate corner braces (Figure 1) between the differential carrier front crossmember and the frame kickup over the axle shafts which provide increased lateral stiffness at the rear suspension attachments.

All the welds should be full length arc welds, since the production frame has skip welding on it. (Figure 2)

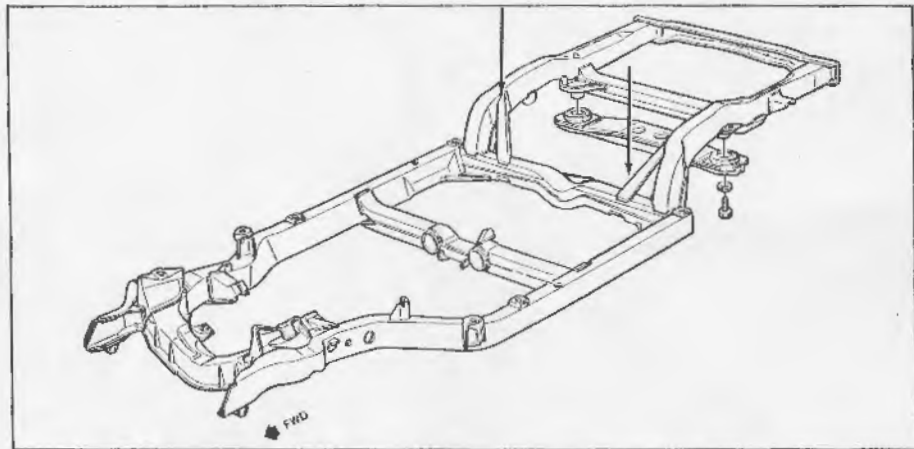

Figure 1 — Desired corner braces providing increased lateral stiffness.

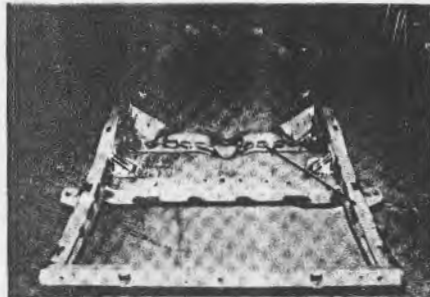
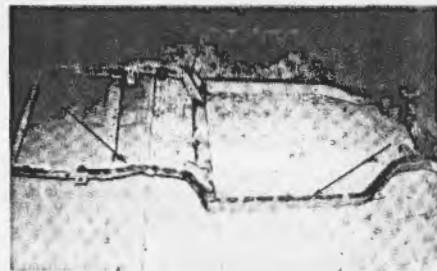

Figure 2 — Frame showing the full length arc weld.

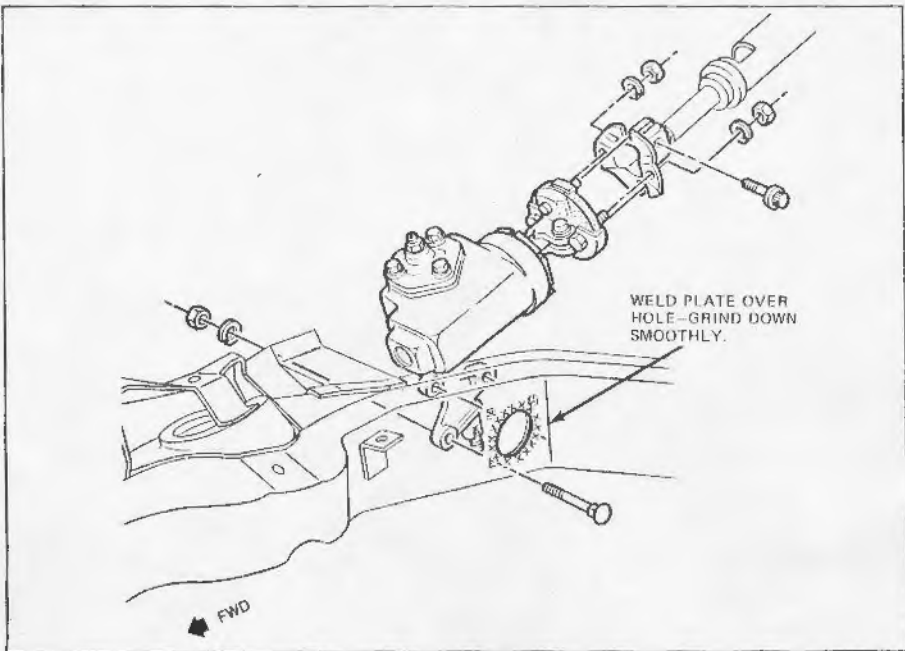

Figure 3 — Required frame reinforcement near the steering gear assembly.

All Manufacturing holes or clearance holes that are not to be used should be plated over and welded. Of particular importance is the hole (Figure 3) near the steering gear in the left side rail which should be filled with a plate, welded and then ground smooth to prevent tire interference.

An automatic transmission frame is recommended because it has a removable crossmember (Figure 4). If an automatic transmission frame is used, the clutch cordon shaft bracket must be welded to the frame, and the manual transmission mounting bracket adapted to the crossmember.

Weld in the roll cage which must conform to sanctioning organization safety requirements, as shown in Figure 5. The intent of the roll cage is not only to provide protection for the driver, but to increase the total stiffness, both bending and torsional, of the frame and body assembly.

Therefore, running struts to the front and rear suspension points attachments is mandatory. It is advisable to put a front suspension tie bar, either welded in or bolted in, between the front upper control arm towers to minimize compliance of the upper control arm attachment points.

The torsional rigidity of the flange is also greatly increased by replacing the production rubber engine mounts with a solid engine mounting plate at the front of the block & solid brackets from the clutch housing to the frame.

Gusseting (Figure 6) should be added to the upper control arm towers and the lower control arm attachment channels in the form of "fish plates".

The entire frame and suspension should be painted with a light colored chemical resistant paint such as epoxy after all welding is completed to prevent corrosion and to facilitate detection of frame cracks during subsequent inspections.

Clearance (Figure 7, page 4-4) should be cut in the front coil spring pocket in the frame for the shock absorbers to be used in the car.

The clearance should be checked in both full rebound and full jounce to prevent possible bending of the shock absorber shaft during suspension travel.

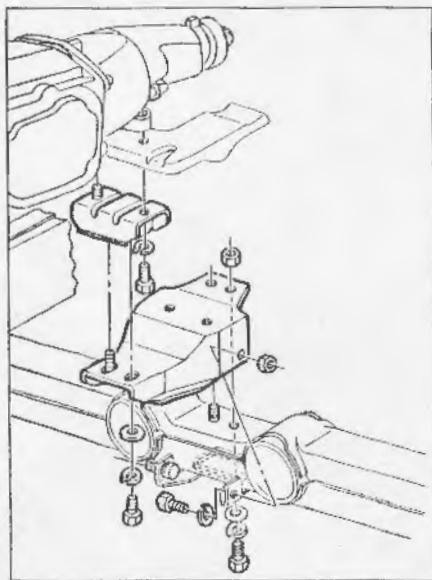

Figure 4 — Installation of manual transmission mounting bracket.

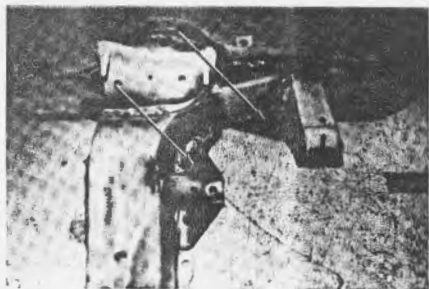

Figure 6 — Weld gussets to crossmembers and lower control arm bracket.

The rear suspension differential carrier mounting crossmember should have the rubber mounts removed and replaced with steel plates. (Figure 8, page 4-4) There is some freedom to adjust the height of these plates to mount the differential carrier further up into the frame. If this is done, the corresponding adjustment should be made in the front differential case attachment.

The differential mount crossmember may also be replaced by a fabricated tube to raise the differential approximately 1 inch higher. The rear frame rails must also be trimmed to raise the bump travel & the shock absorber brackets are relocated upward 1 inch.

The frame should be boxed in at the front frame rails forward of the front suspension crossmember over the stabilizer bar attaching points (Figure 9, page 4-5) to provide adequate stiffness for stabilizer bar loads to be imparted to the chassis.

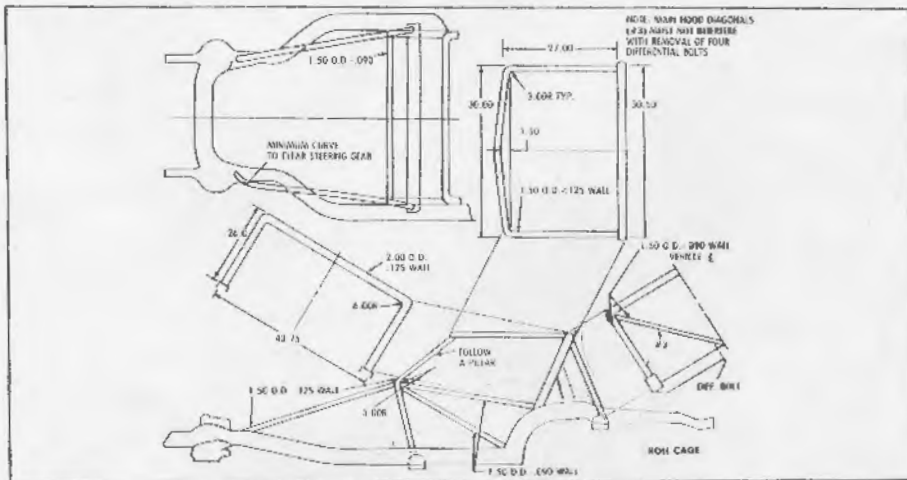

Figure 5 — Typical roll cage welded to the frame assembly.

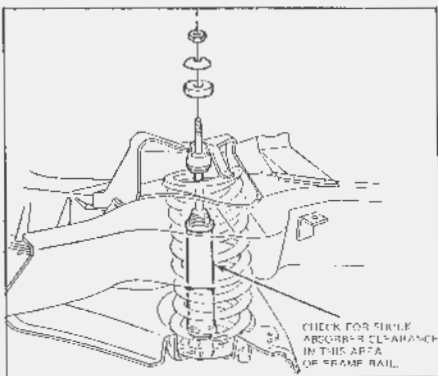

Figure 7 — Area of frame rail requiring shock absorber clearance.

If the rules permit, tire clearance should be provided in the frame rails and the area must be cleaned up with a grinder to prevent sharp surfaces which could possibly cut a tire during cornering. Likewise; at the front the area just aft of the front suspension crossmember should be smoothed up to prevent tire interference.

Front Suspension

Use production upper and lower control arms. Weld stabilizer bar attachments to lower control arm to reinforce the attachment (Figure 10)

Replace the rubber control arm bushings with solid bushings either by fabricating replacement bushings from bronze or high density plastic, using commercially available solid bushing kit, or using rod end joints welded onto the arms.

Provide variable caster-camber adjustment at the upper control arm by means of threaded attachments. If production type of attachments are used, then replace shims with

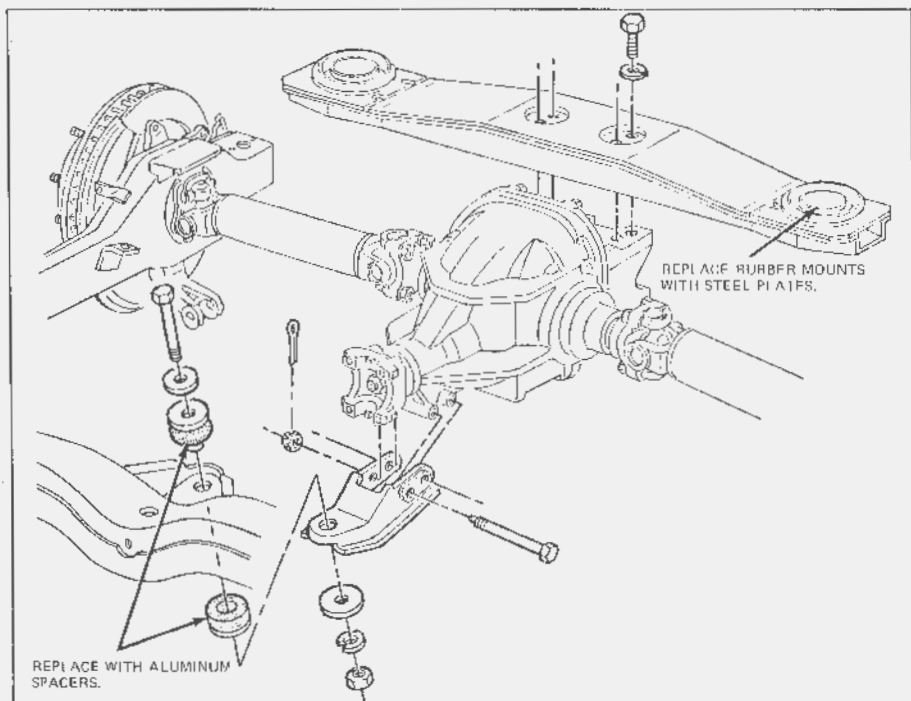

Figure 8 Replacement of rubber parts with solid plates and bushings.

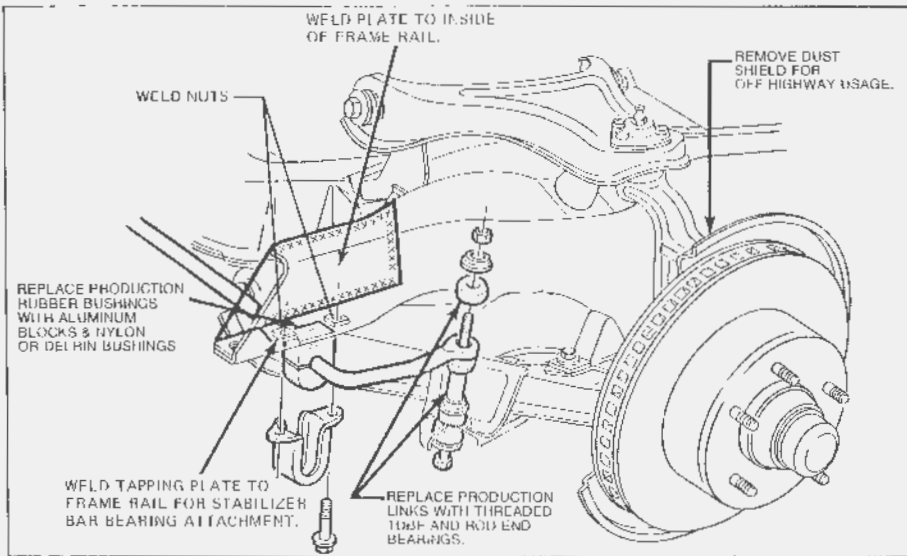

Figure 9 — Weld tapping plate to inside of frame rail for stabilizer bar bearing attachments.

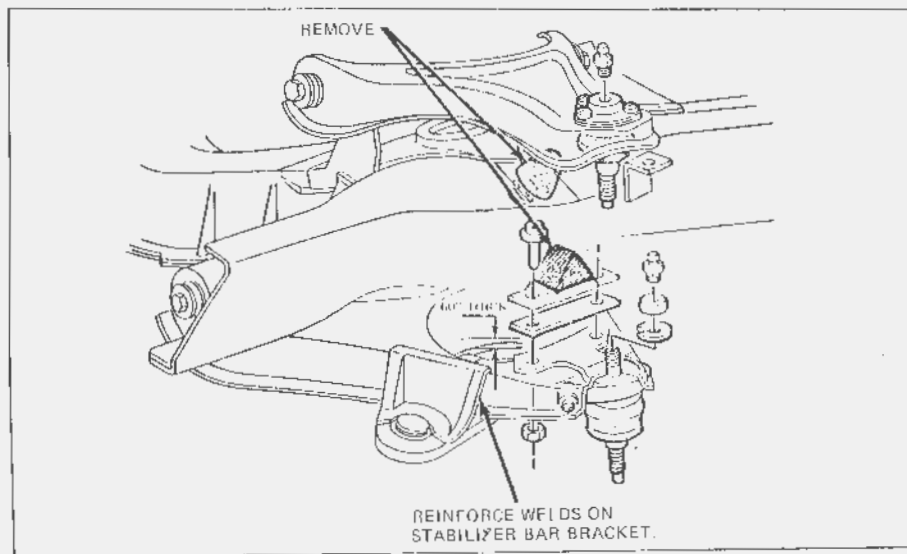

Figure 10 Reinforce welds on stabilizer bar bracket and remove the upper/lower bumpers.

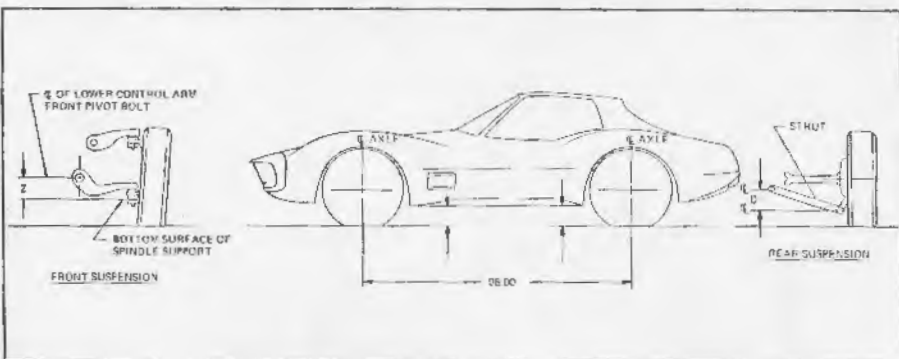

Figure 11 — Proper front and rear vehicle trim heights.

washers to prevent loss of shims if upper control arm shaft adjusting bolts are loose.

Use 1969 or later production Corvette front spindle which incorporates the larger diameter wheel bearings. Adjust wheel bearing end play to .001 max. and use production high temperature type wheel bearing grease. Such as Sinoco Sunaplex 802.

Trim rubber jounce bumper to metal-to-metal (height .60 in.) see Figure 10, page 4-5 or remove entirely if shock absorber and springs allow suspension travel to the point of control arm bottoming on the frame. Rebound control can be limited by means of shock absorber travel restriction or the application of an external stop in the form of metal-to-metal stop at upper control arm to frame contact point or a strap arrangement to lower control arm. Rebound should be limited to prevent the spring from unseating during its rebound travel. Spring usage should be F-41 front spring for applications on all tracks other than highly banked tracks. On high bank tracks, such as Daytona and Talladega, the "Daytona" front spring package should be used. Spring height should be adjusted by either bumping or bulldozing the spring to achieve a front "Z" height of 1" to 1-1/4" with the vehicle full of fuel and driver aboard. (Figure 11) Bulldozing a coil spring is a technique of lowering the design height by fully compressing the spring to a closed coil condition while lightly tapping the coils with a brass hammer. Extreme caution should be exercised during this procedure since the compressed spring is under considerable force. This will provide adequate suspension travel while maintaining the lower front profile for aerodynamic use. Check for bottoming of oil pan and crossmember at full jounce conditions.

Stabilizer bar application can be production bars or bars similar to production manufactured by the individual. In all cases, they should be mounted in a solid bushing material such as aluminum, nylon, or delrin. The links at the end of the stabilizer bar connecting to the lower control arm should be replaced with rod end joints and a threaded shaft to provide noncompliant links and adjustable lengths.

It is desirable to check the "bump steer" of the front suspension to obtain zero toe change during the jounce portion of wheel travel. A production steering linkage may be

adjusted by lowering the outer tie rod point approximately 3/4" which will improve the bump steer curve. An area to watch is possible tire interference between the front tire and the steering arm and/or tie rod end.

When setting the vehicle up after build, the front wheel weight distribution should be as near equal as possible without the stabilizer bar connected. Once the weight has been equalized with the springs installed, the stabilizer bar should be attached and the links should be adjusted so there is zero preload of the front suspension due to stabilizer bar torsion.

Rear Suspension

The differential carrier rear mounting crossbar rework was discussed in the frame preparation section. The rubber differential mounting insulators should be replaced by solid steel plates. The pinion nose front bushing should also be replaced by a solid metal bushing, preferably an aluminum block. Care should be taken to maintain the correct differential case attitude. If the plates have been moved up in the crossmember, this should be duplicated by adjusting the height of the aluminum block the same amount.

Rear suspension torque arms should be replaced with new units purchased from Service. The torque arms should have the parking brake cable mounting bracket removed and the surface ground smoothly. All seams should be completely welded to maintain total strength. The torque arm forward bushing can be replaced with a spherical joint if desired, although many cars run with the production rubber bushing.

It is desirable to install a threaded toe adjustment mechanism in place of the slim pack at the front bushing mounting point. If a threaded adjuster is not used, the late model shims must be used which provide for a cotter pin to hold the shims in place. If tire clearance is required in the torque arm, it is mandatory the torque arm be fixtured before welding to maintain arm alignment. The torque arm section be maintained in the area of the offset and that all material added be of a thicker gage than production. (Figure 12)

The production bushing in the control arm should be replaced with a spherical bearing. Tire clearance in the sus-

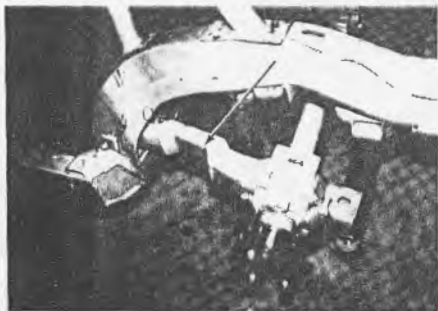

Figure 12 — Reworking rear suspension control arm.

sion control arm should be avoided if possible since undesirable rear wheel steer can result from modified arms.

Use rear spindle part number 3872476 which is a high nickel alloy forging and has proven satisfactory. Use a high pressure grease such as shell alvania EP-2 when building the spindle pack. Set spindle end play to .001" maximum. Delete all the parking brake and dust shield components in the rear spindle assembly as a weight saving measure and to provide additional brake cooling for off highway usage only.

Use the current production 3" diameter axle driveshafts. These units came into production in 1975 and are serviced for all previous Corvettes. Use the cap type attachment instead of the strap type (cap part number 3872909), for attaching the axle to the yoke.

Rework strut rod attachment bracket on the bottom of the axle by welding a plate over the adjustment slot and drilling a single hole to accept rod end joint. Replace the strut rod with a threaded tube using left and right threaded rod end joints. This system provides a noncompliant link as well as positive camber adjustment and control. (Figure 13).

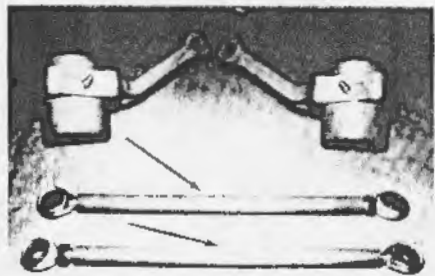

Figure 13 — Rear suspension strut rod replacement.

The lower strut rod attachment should be made with the Corvette heavy duty lower shock mounting pin in place of the production unit for increased shock absorber clearance. Part number of the heavy duty pin is 3829265-66. Use the F-41 rear spring for normal track surfaces. For high bank tracks such as

Daytona and Talladega, use the "Daytona" spring package. When installing the spring, use longer spring hanger bolts made out of high strength steel to provide a means of height adjustment. Set the rear "D" height to 1-1/4" with fuel and driver aboard, as shown on Figure 11.

The use of longer spring bolts allows the adjustment of weight from side to side to equalize corner loads. Trim the rear jounce bumpers to approx. .60" thickness which provides maximum suspension travel while preventing the universal joints from bottoming out during full bump. The production jounce bumpers may be completely removed if the shock absorbers are equipped with rubber bumpers.

If the axle has been moved up in the frame, it may be possible to remove the jounce bumpers entirely. Before this is done, a static check should be made in full jounce position to determine if the universal joints are grounding out. Rebound control should also be checked to make sure universal joints do not ground out in full rebound.

Production rebound control is maintained by shock absorber length. If replacement shock absorbers are used, a check should be made at full rebound to assure universal joints are not grounding out. If the shock cannot do this, a strap or cable should be provided between the control arm and the frame to prevent excessive rebound travel. The production type rear stabilizer bar is satisfactory if the links from the control arm to the stabilizer bar are replaced with rod end joints and threaded shafts to allow adjustment. When installing the bar (Figure 14, page 4-8), make sure the linkage is such that the stabilizer bar will not travel to an "over center" condition in full rebound. It may be necessary to lower the axis of the bar to prevent this.

The F-41 rear spring and the recommended front bar should be used with a 3/4" dia. rear bar. This diameter bar will have to be fabricated to the standard production bar configuration. Care must be taken to provide adequate tire clearance when forming the bar. The "Daytona" spring with recommended front bar can use either a 9/16 production rear bar or possibly a 5/8", depending upon vehicle. It may be necessary to alter these bar diameters slightly to provide the correct balance depending on the individual car and driver preference. In any case, stabilizer mounting bushings to frame should be replaced with a solid material such as delrin, nylon, bronze, aluminum.

It is desirable to replace the shock absorbers with external double adjustable shock absorbers. The early F-41 Corvette heavy duty shocks may also be used. This is a large diameter shock which increases rebound and jounce damping over the standard shock and has greater heat capacity.

CLUTCH AND TRANSMISSION PREPARATION

The following procedures should be followed to insure minimum difficulties and maximum durability from the heavy duty Chevrolet clutch and transmission components.

Clutch

1. The crankshaft pilot bushing should be replaced if the original bushing shows any eccentricity or wear.

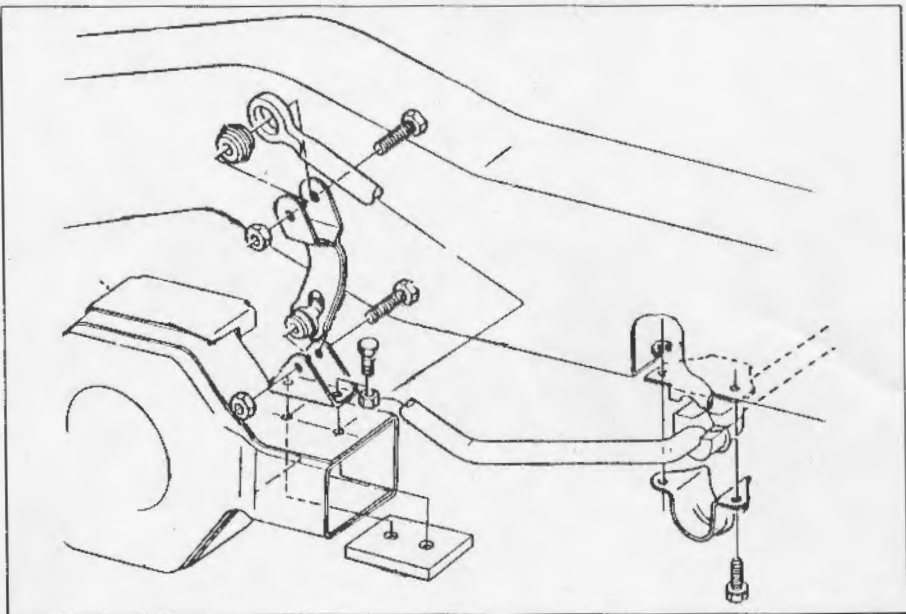

Figure 14 — Rear stabilizer bar installation.

2. The clutch housing transmission mounting face must be parallel to the crankshaft flywheel mounting face or the rear face of the clutch housing should be machined to obtain parallelism.

3. The clutch housing pilot hole for the transmission bearing retainer must be concentric to the crankshaft centerline. Offset dowel pins are available to adjust the concentricity.

The following clutch components have proven to be satisfactory during high performance usage:

1. RPO L-88 nodular cast iron light weight 12-3/4" diameter flywheel (P/N 3991406).
2. Clutch cover and pressure plate (P/N 6273958) using a nodular iron pressure plate, flat drive strap, higher release load spring and nominal 3200 lb. pressure plate load.
3. Clutch driven plate (P/N 3991428) using a bonded aluminum backed clutch facing, heavy duty splined hub and low height cushion springs.

The clutch driven plate should be checked for any burrs or roughness on the hub splines which might impede movement on the transmission input shaft. It is advisable to "lap" the clutch disc on the clutch gear to remove any burrs.

(Figure 15) The clutch driven plate requires a break-in period to remove friction material "fuzz" which will cause the clutch to release incompletely.

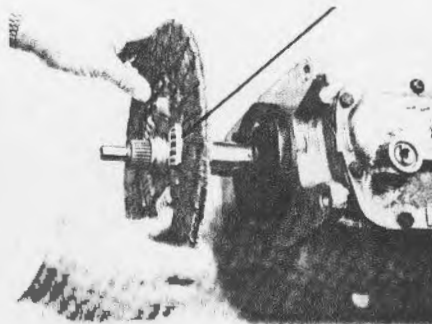

Figure 15 — Lapping the clutch disc on the clutch gear to remove any burrs.

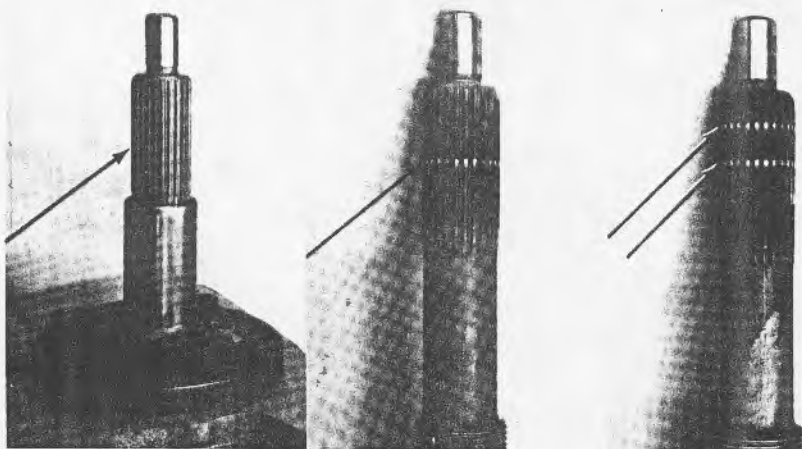

Figure 16 — Illustrated transmission identifying the circumferential grooves on input shaft.

Transmission

The Chevrolet Muncie transmission using a cast aluminum gear case and extension housing was the most durable 4 speed manual transmission offered by Chevrolet for high performance usage. However, the Muncie transmission assembly is no longer produced although all individual components are available from GM Parts Division through Chevrolet dealers. The close ratio Muncie transmission with 2.20:1 first gear ratio, 26 spline input shaft and 32 spline output shaft is recommended for off-the-highway road racing activities. There are three aluminum case Muncie transmissions which may be identified as follows:

1. Heavy Duty Performance (Close Ratio) transmission uses low helix angle gear set, close ratio gears with 2.20:1 first gear, oil drain plug on gear case and no identifying circumferential grooves on input shaft. (Figure 16)
2. Standard Performance Transmission has close ratio gears with 2.20:1 first gear, no oil drain plug on gear case and one circumferential groove on input shaft.
3. Regular Four-Speed Transmission has wide ratio gears with 2.52:1 first gear, no oil drain plug and two grooves on input shaft.

The following special steps should be followed before any transmission is used in competition:

1. Transmission should be thoroughly disassembled for visual inspection as well as magnetic particle and dye penetrant inspection of all components. (Figure 17, page 4-10)
2. Nut or grit blast inside of case to remove casting sand and casting flash.
3. Polish front and rear surfaces of counter gear. (Figure 18, page 4-11)

4. All synchronizer (blocker) rings should be checked for hardness (R_B 75-80 preferred) and checked for roundness either with a dial indicator or with "Prussian Blue" against a cone. (Figure 19, page 4-11)

The blocker ring thread flats should be .002"-.004" wide which can be checked with an optical scale. All burrs should be removed from the blocking ring chamfers. Add six (6) wiping grooves or slots to inside of diameter of blocker ring using a jewelers file. (Figure 20, page 4-11)

Use only blocker rings with small "B" imprinted on face of ring at small end of cone. (Figure 21, page 4-11)

5. Bend tang of counter gear thrust washer to approximately 90° without cracking tang to prevent rotation of washer against case. (Figure 22, page 4-12)

6. Measure run out of counter gear rear thrust surface in case and do not use case if run out exceeds .005". (Figure 23, page 4-12)

7. Special first gear roller bearing unit (P/N 3965752) consisting of reworked 1st gear, special thrust washers and needle bearing is suggested in place of the production 1st gear. (Figure 24, page 4-12)

NOTE: The corrosion preventative coating in the needle bearing must be completely removed with either a hot degreaser or ultrasonic cleaner. The bearing should then be pressure repacked with a high temperature grease, such as shell alvania EP-2.

8. Use 20 lb. side cover detent spring (P/N 3831718). Install TCS switch plug (P/N 3906448) and gasket (P/N 3906462).

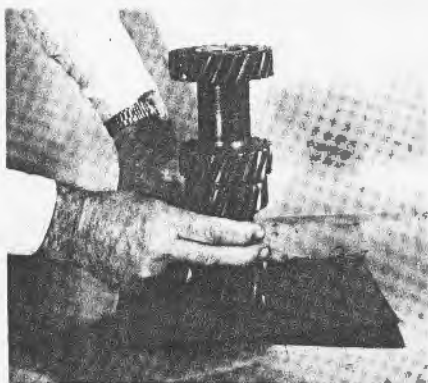

Figure 18 — Polishing front and rear surfaces of counter gear.

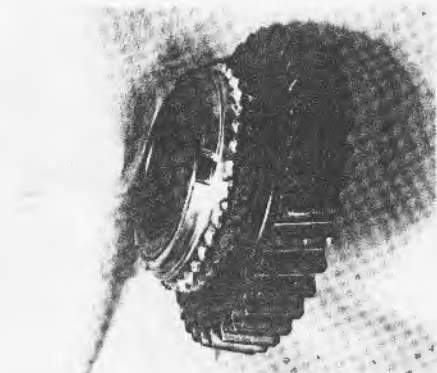

Figure 19 — Cone and blocker ring referenced in Step 4.

9. Texaco 2326 multigear, D-A gear lubricant or similar high quality lubricant should be used on all running surfaces during assembly. Use magnetic fill and drain plugs.

10. Run transmission on spin test rig if possible to insure burnish of gears and proper seating of blocker rings. After transmission oil is warmed up, shift through all forward gears, slowly at first, then progressively faster.

11. Transmission side cover bolts, drain and fill plugs and clutch housing attaching bolts should all be safety wired.

12. Some competitors use a transmission oil cooler for long distance events but may not be necessary if the

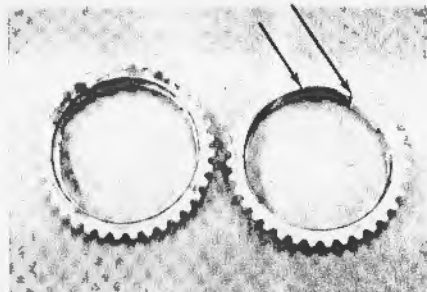

Figure 20 — Blocker ring comparison showing wiping grooves or slot modifications.

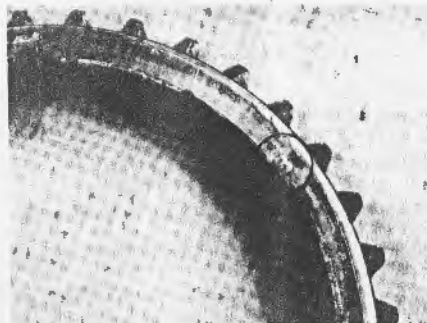

Figure 21 — Blocker ring with small "B" imprinted on ring at small end of cone.

transmission lubricant temperature does not exceed 275°-290°F.

REAR AXLE AND DIFFERENTIAL

The Corvette rear axle has proven to be satisfactory for high performance applications if prescribed inspection and assembly techniques are followed.

The differential should be completely disassembled for visual and magnetic particle inspection especially for heat treatment cracks in the large or "loading" window of the differential case. Grind the edges of this large opening to a smooth contour and shotpeen this surface (Figure 25, page 4-13).

The latest released differential cases P/N 3997926 for gear ratio 2.70:1 to 3.70:1 and 3997928 for gear ratio 3.90:1 to

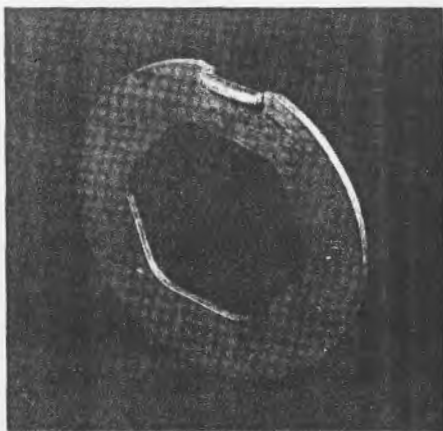
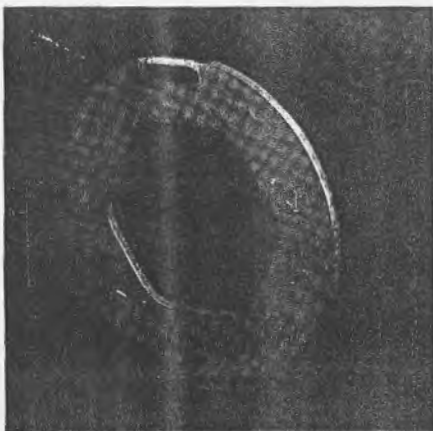

Figure 22 — Comparison of a stock washer and a washer with the desired 90° bend.

5.14.1 which have higher hardness cases should be used for all rear axle rebuilds.

Use heavy duty limited slip kit (P/N 3982240) consisting of 22 friction plates, higher load springs, thicker spring load plate and shot peened differential gears.

"Loctite bearing retainer" should be used to secure the inner and outer raceways of the differential case bearings. Production ring gear bolts and differential bearing cap bolts should also use "Loctite" stud lock compound.

Pinion bearing preload should be set to 8 to 12 in./lb. and differential bearing preload should be 13 to 15 in./lb. The

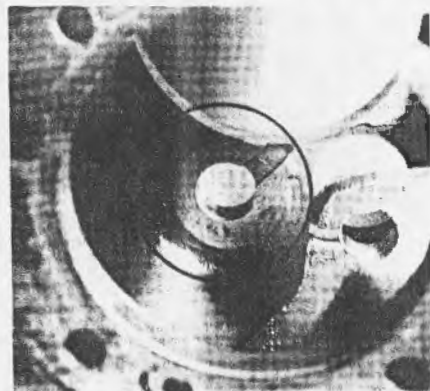

Figure 23 — Counter gear rear thrust surface.

shop manual procedure should be followed for reassembly of the differential.

Use pinion flange (P/N 3879208) which accepts 2-1/4" O.D. propshaft assembly (P/N 3924148). Maximum run out of pinion flange is .005 total indicated run out (T.I.R.) with zero run out desirable for high speed smoothness. Polish and prelube pinion seal contact surface.

Use axle output or drive yoke (P/N 3872922) which is cap type used on all large block vehicles. The yoke end play must be reduced to less than .005" using hardened steel shims which must be fabricated.

Use magnetic plug (P/N 2309473) in filler hole and install steel vent (P/N 3820840) in rear cover pressed into .359-.369 diameter hole. Texaco 2326 multigear lubricant, D-A rear axle

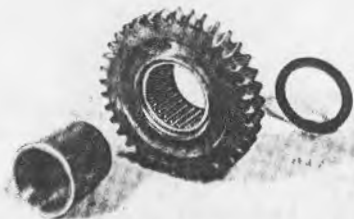

Figure 24 — Rework 1st gear, special thrust washer and needle bearing.

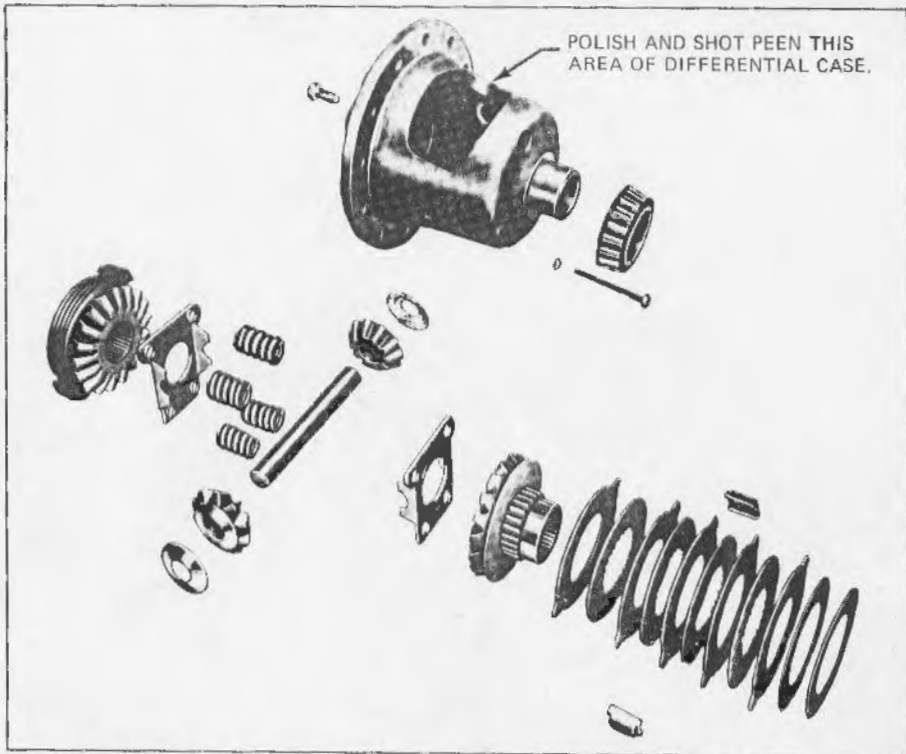

Figure 25 — Exploded view of Corvette positraction.

lubricant or other high quality lubricant should be used during build up and for running.

Gear and bearing break-in on a test stand is recommended consisting of a minimum of two (2) hours running at 1000 to 2000 RPM. The initial break-in oil should be drained and refilled for operation.

A rear axle cooler is suggested for any endurance events. Harrison oil cooler (P/N 3157804) and electric driven circulation pump such as Jabsco #6360 are frequently used by competitors. The cooler should be mounted at about the same height as the differential so the axle will not overflow in case of circulation pump failure.

Axle rear cover may be reworked for cooler lines by drilling and tapping on vertical line $\frac{3}{4}$ " to left of centerline of middle vertical rib, the top hole down 1.28" from crossmember surface and the bottom hole up 1.46" from spring surface. Tap for $\frac{1}{2}$ " pipe thread and install fittings with thread lock, grind off fittings flush with inside of cover.

Lower bushing should have bottom edge of inlet rounded for oil pickup. Cooled oil enters axle through top bushing to spray on ring gear and pinion bearing.

The production differential may also be replaced by a "spool" available from several aftermarket sources which will provide a fully locked rear axle.

SUGGESTED CHEVROLET SERVICE PARTS:

NOTE: See Figure 26, page 4-14) for proper parts identification.

1. Differential Carrier Assembly (with ring & pinion)

3.08	3899132
3.70	3899137
4.11	3899139
4.56	3899141
—	3917861*

*Without Ring & Pinion

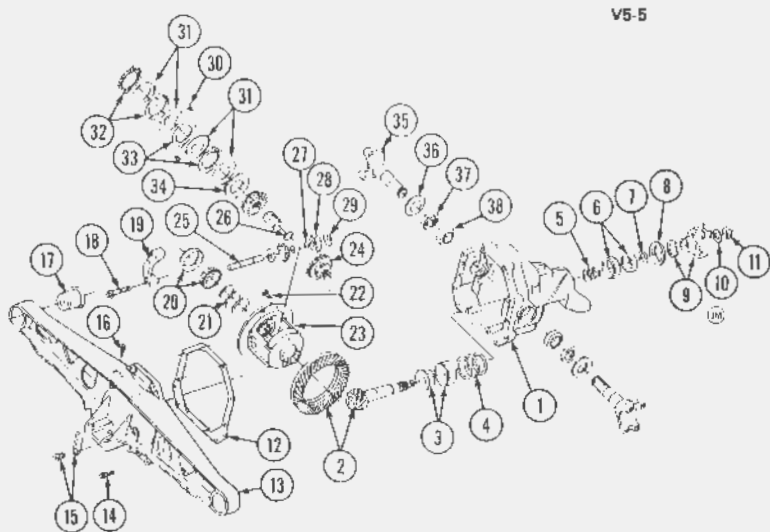

V5-5

V5-6

Figure 27 — 1980-82 Corvette Differential Carrier (DANA)

1. CARRIER, Diff W/Cap	5.505	22. SCREW, Ring Gear (3/8 24 x 13/18")	5.531
2. GEAR, Ring & Pnc	5.528	23. CASE, Diff	5.510
3. BEARING, Pnc	5.484	24. GEAR, Diff Side	5.528
4. SHIM KIT, Brg Preload Adj	5.460	25. SHAFT, Pinion	5.517
5. SHIM (Part of #4)	N.S.	26. RING, Diff Side Gear Snap	5.537
6. BEARING, Pnc Otr Proloud	5.447	27. HING, Snap	N.S.
7. SLINGER, Pnc Otr	5.484	28. PINION, Diff	5.526
8. SEAL, Pnc Oil	5.469	29. WASHER, Diff Pinion Thrust	5.642
9. FLANGE, W/Detector, Prop Shaft Pnc	5.545	30. REAMER, Diff CLutch ("1)	5.511
10. WASHER, Pnc Nut	5.812	31. PLATE KIT ("1)	N.S.
11. NUT (3/4"-16)	8.917	32. PLATE KIT ("1)	N.S.
12. GASKET, Diff Carrier Cover	5.389	33. PLATE KIT ("1)	N.S.
13. COVER, Diff Carrier (Carrier Mtg Mbs)	7.039	34. PLATE KIT ("1)	N.S.
14. SCREW, Carrier Cover	5.398	35. SHAFT, Yoke-LH (Use W/14020911)	5.425
15. PLUG, Filler	5.400	SHAFT, Yoke RH (Use W/14020911)	5.425
16. VENT, Breather	5.387	SHAFT, Yoke-Lh (Use W/14020912)	5.425
17. BUSHING, Diff Carrier Cover	5.381	SHAFT, Yoke RH (Use W/14020912)	5.425
18. SCREW, Brg Cap	5.506	36. SHIELD, Stone (Part of #35 Shatt)	N.S.
19. CAP (Part of #1 Corner)	N.S.	37. SEAL, Inner Yoke	5.530
20. BEARING, Diff		38. BEARING, Yoke Inner	5.428
21. SHIM KIT, Brg Preload	5.537		

NOTE 1: Part of Plate Kit 5 511

2. Ring and Pinion Gear Set

Ratio	Unit Part No.	Ring/Pinion
2.73	3961431	(41/115T)
3.08	3961418	(37/112T)
3.36	3961423	(37/111T)
3.55	3961420	(32/91)
3.70	3961419	(37/107)
3.90	3970551	(39/101)
4.11	3961421	(37/97)
4.56	3961424	(41/91)
4.88	3963840	(39/81)
5.14	3970552	(38/71)

3. Differential Case (Without Internal Gears)

Ratio	Part No.
All up to & incl 3.70	3997976
4.11	3997978
4.56	
3.90	

4. Bearing Assm.

	Assy. No.
Diff. Side (Timken No.)	7451140
Fr. Pinion (Timken No.)	7450984
Rear Pinion (Timken No.)	7451155

5. Miscellaneous

Pinion Seal (Viton)	3982733
Pinion Flange	3829/68
Diff. Conversion Kit (H.D.)	3982740
Fill Plug (Magnetic)	2309473
Drain Plug	
Vent	3826840
Oil Cooler Line Fittings (Weatherhead No.) (if applicable)	3220XRXS

6. Recommended Bolt Torques

Ring Gear to Differential Case Bolts	40-60 lbs. ft.
Cover to Differential Carrier	35-55 lbs. ft.
Differential Cap to Carrier	50-60 lbs. ft.

hydraulic system and bleed, and fluid is adequate cooling.

Components

When selecting the components for the system, a decision as to whether to use a manual brake system or a power boost system should be made. The manual brake system is generally a more responsive system but has a penalty of higher pedal effort. If a Chevrolet vacuum power boost unit is used, the noise attenuator (filter) packing around the push rod opening should be removed to improve the response time of the diaphragm during pedal application.

The production Corvette master cylinder or a similar 1-1/8" diameter master cylinder with a larger reservoir capacity can be used. An early Chevelle service master has a similar bore but larger capacity. The increased capacity insures adequate fluid for use with worn pads, such as might be encountered in a long distance race. A replacement master cylinder with 1-1/4" diameter piston can be adapted to provide increased hydraulic fluid displacement if a progressive loss of pedal height is encountered during an endurance event. These larger diameter master cylinders are used on 1974 or 75, 20 and 30 series Chevrolet trucks.

Extreme care should be taken to adjust the master cylinder push rod so the piston fully returns to rearward position when the brakes are released. The master cylinder mounting holes must also be slotted to attach to the firewall or power brake booster.

If a replacement master cylinder is used, care should be taken to remove the pressure reserve valve in the rear circuit if the master is from a disc drum type braking system. When installing the master cylinder in the car, care should be taken to insure a full stroke in the master before the pedal bottoms out of the toe pan. If this is not happening, lengthen the push rod to insure the piston bottoming out in the master cylinder bore prior to the pedal hitting the floor.

All flexible brake lines should be replaced with new production lines or with Aeroquip brand steel flexible lines. This is done in order to minimize volume change due to hose expansion during pressure applications.

When installing the rotor and caliper assemblies on the vehicle, the rotor should be centered in the caliper housing. If the production rotor and the spindle do not give this condition, then shim the rotor or caliper mount to position the rotor in the center of the caliper housing. It is useful to polish the forward edge of the opening in the caliper housing and the leading edge of the brake shoes to a smooth finish and apply a lubricant such as Molykote to reduce the friction between the pad and caliper housing during brake application.

BRAKE SYSTEM

The braking system is one of the main component systems on a vehicle and its proper operation is imperative to the performance of a competitive car.

There are three basic areas to the brake system. First is the correct mechanical components, second is a proper

Hydraulics

The second phase of the brake area is the bleeding of the hydraulic system. It is very essential that all the air be removed from the system in order to maintain a firm pedal under all braking applications. The most important item to remember during bleeding a brake system is to use clean new brake fluid since brake fluid will absorb moisture from

the air which reduces the boiling point. Due to the extreme braking temperatures encountered in competition, only DOT approved 550° boiling point brake fluid should be used. Due to an affinity for moisture of any glycol base hydraulic fluid, regular fluid changes are recommended to avoid possible vapor lock of the hydraulic system under extreme temperature operation. Care should be taken when pouring the fluid into the master cylinder to prevent the formation of small bubbles which can become trapped in the system. When bleeding, either by pressure bleed system or by manually stroking the brake pedal, tap the caliper housings with a small rubber hammer to free up any lodged air bubbles that may get caught in the calipers. Use sufficient fluid to purge the system completely and insure complete elimination of any air bubbles.

CORVETTE CHASSIS MODIFICATIONS

These specifications are intended to provide guidance in modifying a Corvette chassis and suspension for use in limited off-road gymkhana or solo slalom events. The resultant highway ride will be noticeably harsher than a production Corvette but steering response and handling will be more suitable for off-highway activities.

Chevrolet currently offers a production option (RPO) FE7 for the Corvette which consists of larger diameter front and rear stabilizer bars (sway bars) and higher rate (stiffer) front and rear springs.

Following is a comparison of the standard Corvette and RPO FE7 chassis components:

	Standard	1973-74 RPO FE7	1975 RPO FE7
Front Stabilizer Bar Part #	354930	3871318	351586
Front Stabilizer Bar Diameter	1 3/16"	7/8"	1-1/8"
Front Stabilizer Bar Bushings (2)	3923674	3923674	351586
Rear Stabilizer Bar Part #	-	3967713	351587
Rear Stabilizer Bar Diameter	-	5/8"	44"
Rear Stabilizer Bar Bushing (2)	-	480912	351600

In addition, the following front stabilizer bars are available for optional chassis tuning:

Part Number	Bar Dia. (in.)
3831971	3/4
334930	13/16
3871318	7/8
351586	1-1/8

Stabilizer bar bushings must be fabricated for the above optional diameter bars.

Ventilation

The final facet of building a brake system is to provide adequate ventilation for the rotors. This translates into having effective air ducts to direct cooling air to the brake rotors. In the front, pull the air from the front spoiler assembly ducting it through 3/4" hose to the center of the rotor. The air being ducted to the center will be pumped through the vanes of the rotor by centrifugal force and provide cooling over all of the surface area of the rotor. It may be useful to direct a stream of cooling air to the surface of the rotor itself.

Ducts may be used in the rear if required. The ducting need not be as elaborate in the rear as it is in the front. This would depend upon vehicle application and drivers use of the brakes.

An adjustable brake pressure regulator valve (PN 387944) is recommended for the rear brake hydraulic system to prevent rear brake lock up. The adjustment procedure and limitations for the brake proportioning valve are shown in figure 28.

The following chassis springs are also available:

	Part Number	Rate #/In.
Production Front	346939	280
HPO F41 Front	3832518	550*
"Daytona" Front	3988032	850*

*Towers vehicle approximately one inch

Production Rear	356825	140
F 41 Rear	354130	305

Suggested initial suspension geometry settings for the Corvette are:

Front and Rear Caster	1 ± 1/2
Front Caster	+1 ± 1/2
Toe in (Total)	1/16" ± 1/32"

Optimum front and rear suspension settings are normally determined by tire tread wear patterns and by measuring the operating temperature profile if a tire pyrometer is available. Manufacturer's recommendations should be followed for tire inflation pressure.

Multi-position adjustable shock absorbers available from several after-market suppliers are generally recommended. Clearance between optional shock absorbers and suspension coil springs and spring tower should be carefully checked during full wheel travel. Spring tower modification and bump rubber rework for Koni shock absorber clearance as shown.

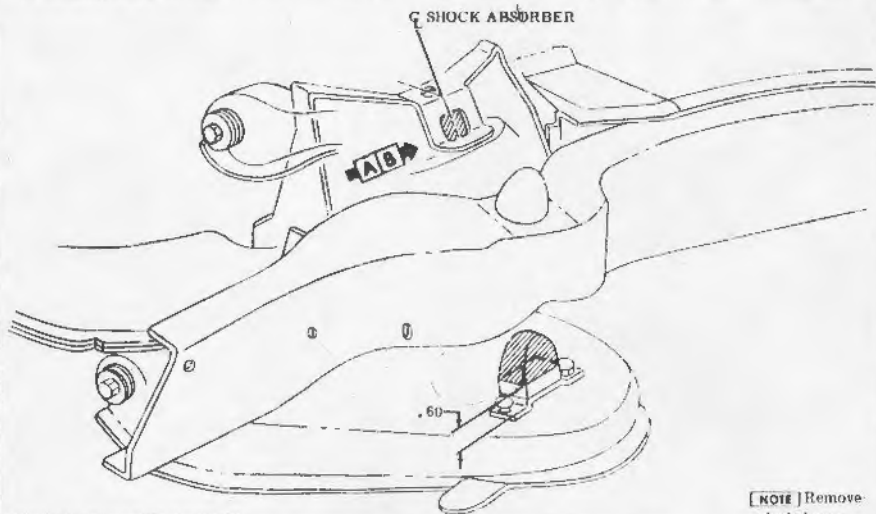
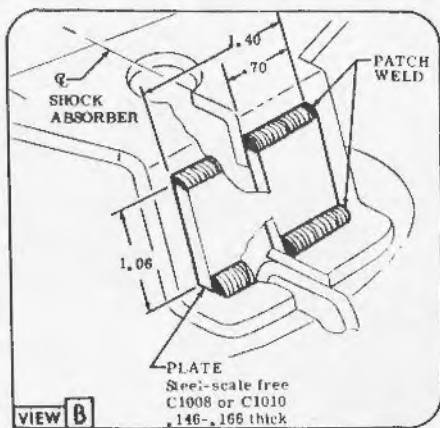
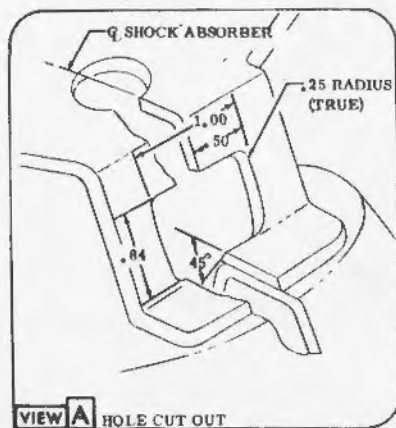
HEAVY DUTY SUSPENSION INSTRUCTION SHEET
CORVETTE

SHOCK CLEARANCE REWORK

SEE SHOP MANUAL FOR REMOVAL AND INSTALLATION OF SHOCKS AND SPRINGS.

[NOTE] Remove shaded area.

INSTRUCTIONS

ADJUSTABLE PROPORTIONING VALVE

This new adjustable proportioning valve is designed to control front-to-rear brake balance on race cars and other off-road vehicles. Applications include oval dirt-track cars, stock cars, road course sports cars and any other type of racing where track surface conditions vary, necessitating a change in brake system balance.

The valve is easily adjusted, no tools required, and features an infinitely variable "knee point" from 100 to 1000 psi.

INSTALLATION

To achieve the maximum benefit from the adjustable feature, it is recommended that the valve be installed inside the car, within easy reach of the driver. Mounting attitude is not critical. The valve should be plumbed into the rear brake system, between the master cylinder and rear brakes, downstream of any differential warning valve, if one is present. The brake tube from the master cylinder, if one is present, connects to the top port on the valve (marked "IN"), and the rear brake tube connected to the bottom port (marked "OUT"). Both the inlet and outlet ports are tapped for 7/16-24 tube nuts and will accept 3/16 or 1/4" O.D. flared tubing. Mounting is accomplished by using the two 5/16" holes.

ADJUSTMENT

Brake balance is varied by rotating the adjusting knob: clockwise to increase rear brakes, counterclockwise to decrease rear brakes. It is recommended that the valve be initially set at its minimum position (fully counterclockwise), and be adjusted upwards, under actual track conditions, until the front-to-rear balance is optimum. After this initial setting is made, only fine tuning will be required to compensate for varying track surface conditions.

Caution: Do not use copper tubing, copper can flex and break. Steel tubing with double flared ends is recommended. (SAE specification J527 and FMVSS 116.)

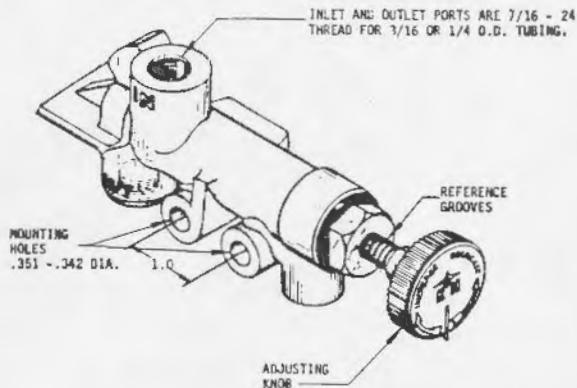
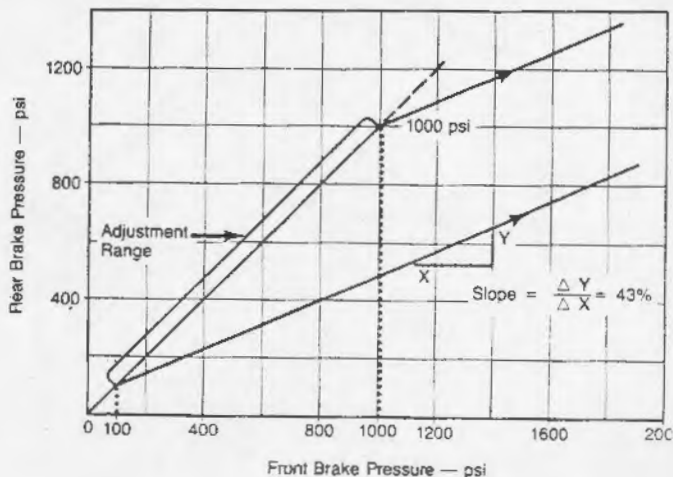

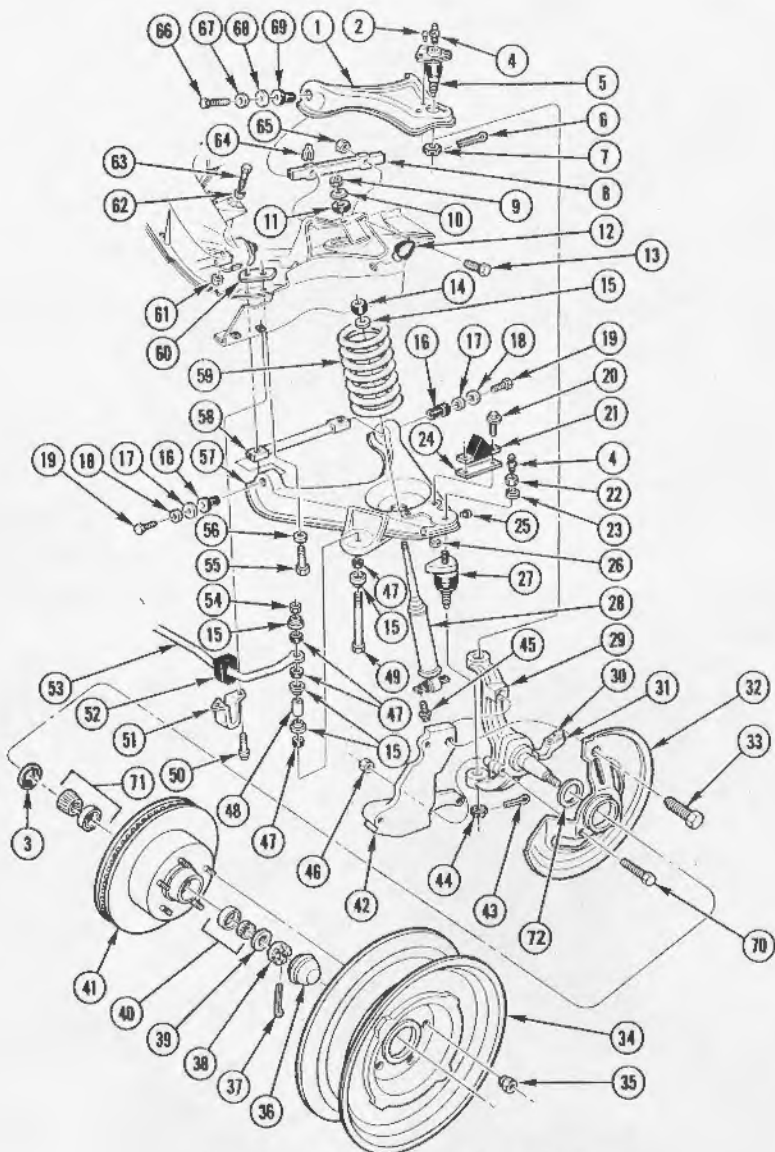

Figure 30 — 1965-82 Corvette Front Suspension (Typical)

1970-82 Corvette Front Suspension (Typical)

1.	ARM ASM., Upper Steering Knuckle	6.168
2.	RIVET (1/4" x 3/4")	8.967
3.	SEAL ASM., Frt. Whl. Brg.	6.326
4.	FITTING (1/2"-28)	6.984
5.	STUD UNIT, Upper Ball Replacement	6.164
6.	PIN, Cotter (1/4" x 1")	8.938
7.	NUT (1/2"-20)	8.917
8.	SHAFT, Unit, Upper Control Arm	6.164
9.	NUT (1/2" - 14)	8.915
10.	WASHER, Frt. Upr. Abs. (1 1/2" I.D. x 1 1/2" O.D.)	7.347
11.	GROMMET, Frt. Upr. Abs. Link	7.388
12.	BUMPER, Upr. Control Arm	6.176
13.	BOLT, Upr. Control Arm (1/2"-13 x 2 1/4")	6.178
14.	GROMMET, Frt. Absorber	N.S.
15.	RETAINER, Stab. Link Grommet	7.389
16.	BUSHING, Lwr. Control Arm (1 1/2" I.D. x 1 1/2" O.D.)	6.170
17.	RETAINER, Bushing (1 1/2" I.D. x 1 1/2" O.D.)	6.170
18.	WASHER (1/2" x 1 1/2" x 1/2")	8.931
19.	BOLT (1/2" - 20 x 1 1/4")	8.900
20.	SCREW (1/2" - 18 x 1)	8.977
21.	BUMPER, Lwr. Control Arm	6.176
22.	NUT (1/2" - 20)	N.S.
23.	WASHER (1/2" x 1/2")	8.931
24.	SPACER, Lwr. Control Arm Bumper	6.176
25.	RIVET, Strg. Knu. Lwr. Control Arm (1/2" - 1)	N.S.
26.	NUT (1/2" - 18)	8.916
27.	STUD UNIT, Lower Ball Replacement	6.174
28.	ABSORBER UNIT, Front	7.346
29.	KNUCKLE ASM., Steering	6.020
30.	RIVET, Strg. Knu. Arm Br. Hole Plug (Part of #32)	N.S.
31.	ARM, Steering Knuckle	6.103
32.	SHIELD, Front Disc Splash	5.002
33.	BOLT, Frt. Caliper Adapter Brkt. (1/2" - 16 x 1 1/4")	5.002
34.	WHEEL ASM., Front	5.803
35.	NUT, Wheel Hub Bolt (1/2" - 20)	5.813
36.	GREASE CAP, Frt. Wheel Bearing (2 1/2" O.D.)	6.930
37.	PIN, Cotter (1/4" x 1 1/2")	8.938
38.	NUT, Steering Knuckle Spindle (1 1/2" - 20)	6.022
39.	WASHER, Steering Knuckle Spindle (1 1/2" O.D.)	6.321
40.	BEARING ASM., Frt. Wheel Outer	6.313
41.	DISC, Front Wheel Brake	6.809
42.	BRACKET, Caliper Adapter	5.001
43.	PIN, Cotter (1/4" x 1)	8.938
44.	NUT (1/2" - 18)	8.917
45.	SCREW (1/2" - 18 x 1)	8.900
46.	NUT (1/2" - 20)	8.917
47.	GROMMET, Stabilizer Link (Rubber) (1 1/2" I.D. x 1 O.D.)	7.244
48.	SPACER, Bolt Grommet	7.240
49.	BOLT, Frt. Stab. Shaft Link (1/2"-24 x 5 1/2")	7.240
50.	SCREW (1/2" - 18 x 1 1/2")	8.900
51.	BRACKET, Shaft Front. Rear Frame	7.242
52.	BUSHING, Shaft Front Frame	7.243
53.	SHAFT, Stabilizer Front	7.241
54.	NUT, Stabilizer Link (1/2" - 24)	7.238
55.	BOLT, Strg. Knu. Lwr. Arm	N.S.
56.	WASHER (1/2" x 1 1/2" x 1/2")	8.931
57.	ARM ASM., Lower Steering Knuckle	6.168
58.	SHAFT, Unit, Lower Control Arm	6.169
59.	SPRING ASM., Front	7.412
60.	NUT, Lower Arm (1/2" - 20)	6.172
61.	NUT (1/2" - 18)	8.917
62.	WASHER, Lower Arm (1 1/2")	6.172
63.	BOLT (1/2" - 18 x 2 1/4")	N.S.
64.	SHIM, Upper Arm (1/2")	6.178
65.	NUT (1/2" - 14)	8.917
66.	BOLT (1/2" - 24 x 1 1/4")	8.900
67.	WASHER (1/2")	6.931
68.	RETAINER (Hole) (1 1/2" I.D.)	6.163
69.	BUSHING (1 1/2" O.D. x 1 1/2" O.I.) Upper Cont. Arm	6.164
70.	BOLT (1/2" - 16 x 1 1/2")	5.002
71.	BEARING ASM., Inner	6.311
72.	GASKET, Splash Shield	6.002

1963-79 Corvette Rear Suspension (Typical)

1. MEMBER, Hr Susp Mtg Cross	5.300	46. CLIP, Parking Lvr	6.056
2. BOLT (1/2" x 14 x 1 1/4")	6.900	47. WASHER, Pivot Pin	5.158
3. WASHER (1/2")	6.929	48. STRUT, Parking Brake	5.160
4. BUMPER, Rr Spring	7.535	49. SHOE UNIT, Parking Brake	5.017
5. NUT (1/2" x 16)	6.760	50. PIN, Brake Shoe	5.043
6. NUT (1/2" x 20)	5.829	51. PLATE, Brake Shoe Guide	5.045
7. PIN, Rr, Whl Spindle	8.939	52. BOLT (1/2" x 20 x 2")	5.056
8. WASHER (1/2")	5.830	53. RIVET, Spindle	N.S.
9. FLANGE, Rr, Whl Spindle	6.806	54. BOLT (1/2" x 20 x 1 1/4")	6.900
10. DEFLECTOR, Rr Whl Spindle	6.425	55. HOUSING ASM., Brake Culliper	4.665
11. SHIELD, Rr Whl Inr Brg	5.822	56. DISC, Rr Whl Brake	5.809
12. BOLT, Hr Spring	7.629	57. SPINDLE, Rr, Whl	5.808
13. SEAL, Rr Inr Brg	6.822	58. SEAL, Rr Whl Otr Brg	6.822
14. BOLT (1/2" x 24 x 2 1/4")	6.002	59. BEARING ASM., Rr Whl Otr	5.855
15. BEARING, Rr Whl Inr	5.856	60. SPACER, Brg	5.816
16. SHIM, Rr, Whl	5.855	61. SOCKET, Adj. Screw	5.111
17. ARM, Torque Control	5.362	62. SCREW, W-Nut Parking Brake	6.110
18. BOLT (1/2" x 16 x 1 1/4")	6.900	63. SPRING, Parking Brake	5.026
19. WASHER (1/2" x 16 x 1 1/4")	6.931	64. WHEEL ASM., Rr	5.803
20. BOLT (1/2" x 18 x 1 1/4")	6.900	65. NUT (1/2" x 20)	5.813
21. LINK, Rr, Stab. Shaft	5.415	66. ABSORBER UNIT, Rr, Shock	7.345
22. BOLT (1/2" x 16 x 1 1/4")	6.900	67. BOLT (1/2" x 20 x 2 1/4")	7.347
23. BOLT (1/2" x 18 x 1 1/4")	6.900	68. WASHER (1/2")	6.831
24. SHAFT, Rr Stab	7.241	69. NUT (1/2" x 20)	6.916
25. BUSHING, Rr, Stab. Shaft	7.243	90. SHAFT, Hr Whl Spindle	5.381
26. BRACKET, Stab. Shaft	7.242	91. GROMMET, Shk. Abs. Link Rr Lwr	7.388
27. BUSHING, Rr Stab.	7.243	92. GROMMET, Shk. Abs. Link Rr	7.388
28. NUT (1/2" x 16)	6.916	93. WASHER (1/2" x 1/4")	6.931
29. BUSHING, Rr Stab.	7.243	94. NUT (1/2" x 20)	5.383
30. BRACKET, Hr Stab. Shaft	7.242	95. STRUT, Rr Whl Spindle Supt	5.415
31. NUT (1/2" x 16)	6.916	96. CAP, Bushing	6.170
32. PLATE (3 x 1/2" w/2 Holes)	7.246	97. CAM, Spindle Supt. Strut	5.417
33. RETAINER, Otr. Rr Spring	7.545	98. BOLT (1/2" x 16 x 1/4")	6.900
34. CUSHION, Rr Spring	7.545	99. WASHER (1/2")	6.931
35. RETAINER, Inner	7.545	100. WASHER (1/2")	6.929
36. SUPPORT, Cont. Arm to Spindle	5.360	101. BRACKET, Rr Whl Spindle	5.380
37. PIN (1/2" x 1 1/4")	6.938	102. CAM, Rr Whl Spindle	6.172
38. NUT (1/2" x 18)	6.917	103. CAP, Bushing	6.170
39. PLATE, Parking Brake	5.001	104. WASHER (1/2")	6.931
40. WASHER (1/2")	6.931	105. NUT (1/2" x 20)	5.382
41. NUT (1/2" x 24)	6.915	106. CUSHION, Diff. Carrier Mtg.	9.023
42. BRACKET, Brake Flange Hr	5.001	107. NUT (1/2")	6.915
43. PIN (1/2" x 1")	6.938	108. WASHER (1/2")	6.931
44. NUT (1/2")	N.S.	109. BOLT (1/2" x 20 x 4 1/4")	6.383
45. WASHER (1/2" x 6 1/4" x 5/32")	6.931	110. PLATE, Body Mtg. Cushion	N.S.
46. WASHER (1/2")	2.277	111. CUSHION, Diff. Carrier Mtg.	9.023
47. PIN (1/2" x 4 1/4")	6.938	112. WASHER (1/2")	6.164
48. SHIM, Rr Susp Torque	5.380	113. BRACKET, Diff. Carrier Mtg.	5.600
49. PLATE, Rr, Susp Torque	5.381	114. NUT (1/2" x 20)	0.002
50. RETAINER, Torque Arm Bshg	6.361	115. PIN (1/2" x 1")	6.938
51. BUSHING, Upr. Hr	5.381	116. BOLT (1/2" x 14 x 2 1/4")	6.900
52. WASHER (1/2")	2.277	117. BEARING ASM., (Part of #120)	6.548
53. BOLT (1/2" x 20 x 1 1/4")	5.383	118. RING, U-Joint (Also Part #120)	5.586
54. SHAFT, Axle	5.420	119. SEAL, U-Joint (Also Part #120)	5.560
55. PIN (1/2" x 3 1/4")	6.938	120. REPAIR KIT, U-Joint	5.548
56. NUT (1/2" x 18)	6.917	121. YOKE, U-Joint Sleeve Fit	5.555
57. LOCK, Rr Axle U-Joint	6.428	122. SHAFT, Hr Propeller	6.544
58. SPRING, Leaf Type Rr	7.503	123. SHAFT, Propeller Shaft	6.586
59. BOLT (1/2" x 20 x 1 1/4")	6.900	124. BOLT (1/2" x 24 x 1 1/4")	6.586
60. REPAIR KIT, Rr Whl. Dr. Shaft U-Joint	6.428	125. BOLT (1/2" x 12 x 3 1/4")	6.900
61. FLANGE, Rr Whl U-Joint	6.426	126. WASHER (1/2" x 1 1/4")	6.931
62. SEAL, Yoke Brg (1 1/4" x 2 1/2") (Also Part of #60)	5.430	127. NUT (1/2" x 24)	6.015
63. BEARING, U-Joint (Also Part of #60)	6.428	128. WASHER (1/2")	6.929
64. LOCK RING, U-Joint (Also Part of #60)	6.586	129. PLATE, Rr Spring Anchor	7.518
65. LEVER ASM., Parking Brake	6.149	130. CARRIER ASM., Diff	5.505
		131. SPACER, Trunion Brg	5.586
		132. "U" BOLT (Trunion Finger Dia 3/4")	5.586

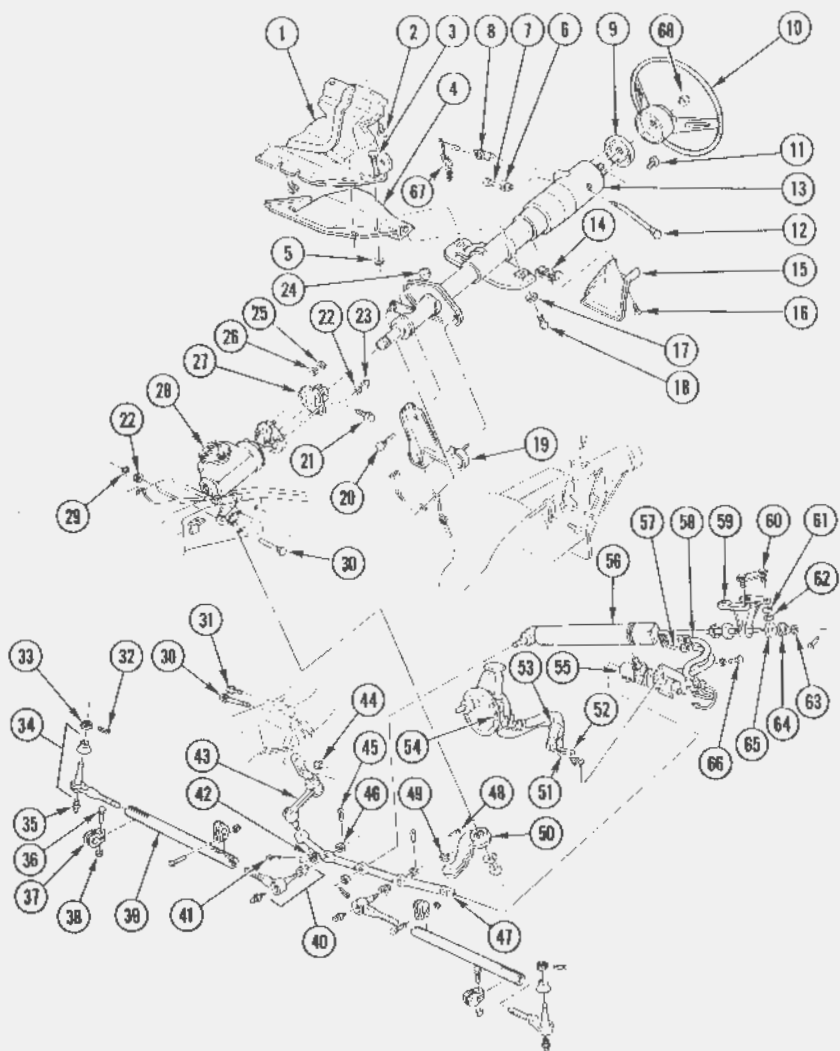
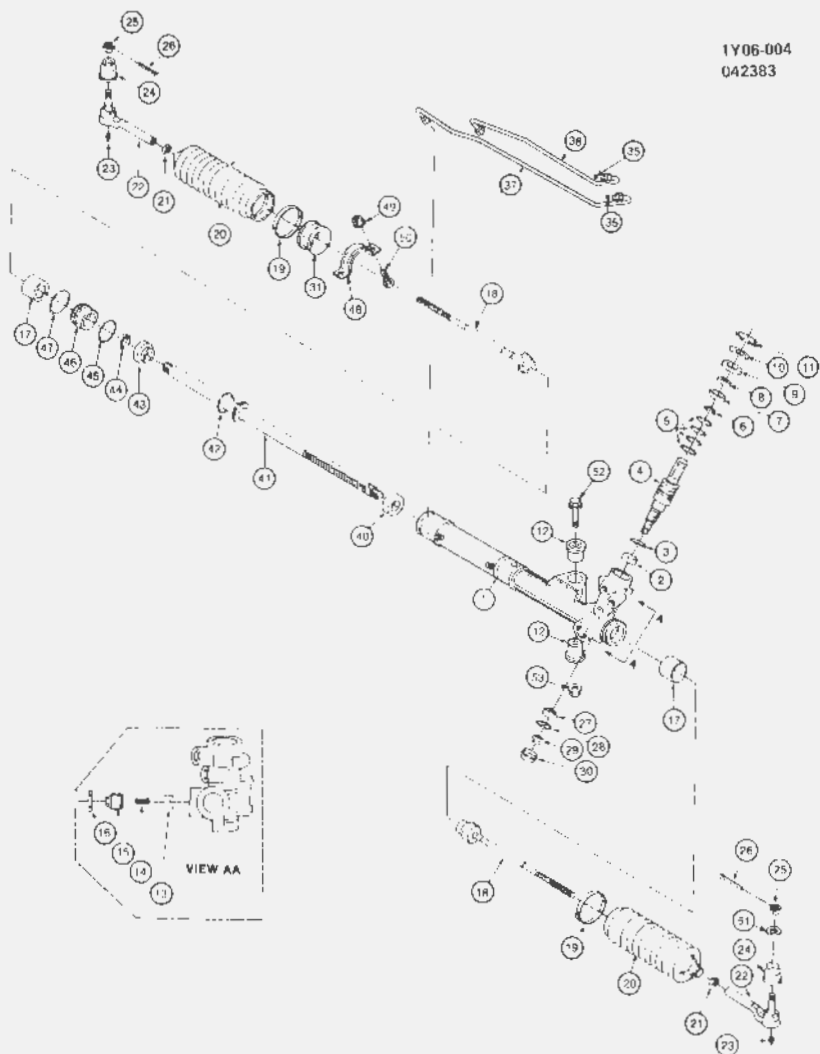

Figure 32 — Corvette Steering Column & Related Parts (Typical)

Corvette Steering Column & Related Parts

1.	BRACKET, Strg. Column Supt	6.760
2.	SCREW ASM., Strg. Col. Supt Brkt ($\frac{1}{8}$ " -18 x 1")	N.S.
3.	BOLT, Strg. Column Supt Brkt	N.S.
4.	SUPPORT ASM., Strg. Column	6.760
5.	NUT ($\frac{1}{8}$ " -18)	8.917
6.	KNOB ASM., Traffic Hazard Warning	2.575
7.	SCREW, Knob to Strg. Column	8.909
8.	LOCK SET PKG., Ignition	2.188
9.	COVER, Strg. Col. Sraft Lx	6.600
10.	WHEEL ASM., Steering	6.613
11.	BOLT (#5 -32 x $\frac{1}{2}$ ")	8.977
12.	LEVER, w/ Knob, Direct Signal Lamp	2.897
13.	COLUMN ASM., Steering	6.518
14.	RETAINER, Trans. Cont. Shaft	2.898
15.	COVER, I/P Lwr. Strg. Column (Paint to Match)	6.518
16.	SCREW, I/P Lwr. Strg. Col. Cvr. ($\frac{1}{8}$ " -18 x $\frac{1}{2}$ ")	9.282
17.	WASHER, Strg. Col. Supt	N.S.
18.	BOLT ($\frac{1}{2}$ " -16 x 1")	6.900
19.	BRACKET ASM., Trans. Cont. Lk	4.070
20.	BOLT ($\frac{1}{4}$ " -18 x $1\frac{1}{2}$ ")	N.S.
21.	BOLT, Steering Shaft U-Joint ($\frac{1}{2}$ " -24 x $1\frac{1}{2}$ ")	6.625
22.	WASHER ($\frac{1}{2}$ " x $\frac{1}{4}$ ")	8.931
23.	NUT ($\frac{1}{2}$ " -24)	8.915
24.	NUT ($\frac{1}{8}$ " -18)	8.917
25.	NUT ($\frac{1}{8}$ " -24)	8.916
26.	WASHER ($\frac{1}{8}$ " x $\frac{1}{4}$ ")	8.931
27.	FLANGE ASM., Strg. Gear Shaft Uptr	6.526
28.	GEAR ASM., Steering	6.508
29.	NUT ($\frac{1}{2}$ " -24)	8.915
30.	BOLT, Strg. Gear to Frame ($\frac{1}{2}$ " -24 x $4\frac{1}{2}$ ")	8.509
31.	BOLT, Strg. Relay & Tie Rod to Frame ($\frac{1}{2}$ " -24 x $1\frac{1}{2}$ ")	N.S.
32.	PIN ($\frac{1}{2}$ " x 1)	8.938
33.	NUT, Strg. Relay & Tie Rod to Strg. Knb ($\frac{1}{2}$ " -20)	N.S.
34.	END ASM., Tie Rod Outer	6.233
35.	FITTING, Lubricant	8.984
36.	BOLT ($\frac{1}{2}$ " -18 x $1\frac{1}{2}$ ")	8.900
37.	CLAMP, Tie Rod	6.234
38.	NUT ($\frac{1}{2}$ " -18)	8.917
39.	SLEEVE, Frt. Axle Tie Rod	6.232
40.	END ASM., Tie Rod Inner	6.233
41.	PIN ($\frac{1}{2}$ " x 1)	8.938
42.	NUT ($\frac{1}{2}$ " -20)	8.917
43.	LEVER ASM., Steering Idler	6.896
44.	NUT ($\frac{1}{2}$ " -24)	8.917
45.	PIN, Outer ($\frac{1}{2}$ " x $\frac{1}{2}$ ")	6.938
46.	NUT ($\frac{1}{2}$ " x 20 -30)	8.917
47.	KOD ASM., Steering Relay	6.870
48.	PIN ($\frac{1}{2}$ " -1)	8.938
49.	NUT ($\frac{1}{2}$ " -20)	8.915
50.	ANM. Pitman	6.859
51.	HOSE, Pump to Control Valve Inlet	6.670
52.	HOSE, Pump to Control Valve Outlet	6.671
53.	CLAMP, Strg. to Gear Inlet & Outlet	6.672
54.	CLAMP, Hydr. Strg. Pump to Cont. Valve Outlet Hose	6.672
55.	VALVE, Strg. Gear Hydr. w/ Adapter	6.650
56.	CYLINDER, Strg. Gear Hydr. (2 nd or O.L.)	6.676
57.	PIPE, Strg. Cont. Valve to Extend Cyl.	6.670
58.	PIPE, Strg. Cont. Valve to Retract Cyl.	6.670
59.	BRACKET, Frame, Hydr. Strg. Cyl.	6.575
60.	REINFORCEMENT, Frame Brkt	6.575
61.	WASHER ($\frac{1}{2}$ " -18)	8.931
62.	NUT ($\frac{1}{2}$ " -18)	8.916
63.	NUT, Frame Brkt. ($\frac{1}{2}$ " -24)	6.676
64.	WASHER, Hydr. Strg. Cyl. to Frame	6.561
65.	GROMMET, Hydr. Strg. Cyl. to Frame Brkt	6.561
66.	SPACE, Hydr. Strg. Cyl. to Frame Brkt	6.561
67.	KEY, blank	2.187
68.	NUT, Hex ($\frac{1}{2}$ " -18)	8.916

1Y06-004
042383

1Y06-004

Figure 33 — 1984 "Y" RACK AND PINION STEERING - POWER

1Y06-004

1984 "Y" RACK AND PINION STEERING - POWER

1.	6.803	HOUSING, Rack & Pinion Asm	7841632
2.	N.S.	BUSHING, Upper Pinion (Part of #1)(16)	
3.	N.S.	SEAL, Pinion Shaft (Part of #1 & 4)(12,3,6)	
4.	6.550	VALVE, Pinion Asm (Exc FE7)(Incls #2,3,5,9,10)	7841820
	6.550	VALVE, Pinion Asm (W-FE7)(Incls #2,3,5,9,10)	7841821
5.	N.S.	RING, Vlv bdy (Part of #4)	
6.	6.552	RING, Ret, Vlv bdy Rings	7831197
7.	N.S.	ANNULUS, Stub Shaft Brg(3)	
8.	N.S.	BEARING, Hyd Strg Gear, Ndl(3)	
9.	N.S.	SEAL, Stub Shaft (Part of #4)(12,3,6)	
10.	N.S.	SEAL, Stub Shaft Dust(2,3,6)	
11.	6.552	RING, Ret Stub Shaft Seal	7828017
12.	6.786	BUSHING KIT, Mounting	7841634
13.	6.786	BEARING, Rack	7827595
14.	6.622	SPRING, Adjuster (R&P)	7838791
15.	6.622	PLUG, Adjuster	7841283
16.	6.622	NUT, Adjuster Plug Lock	7841284
17.	6.665	RING, Shock Dampener	7841291
18.	6.230	ROD KIT, Inscr Tie (Incls #19,17,21)	7841627
19.	6.242	CLAMP, Boot	7841287
20.	6.242	BOOT KIT, IH & PI (Incl #19)	7841628
21.	N.S.	NUT, Hex (M14 x 1.5) (Part of #48)	
22.	6.233	ROD KIT, Out Tie (Includes #23,24,25,26)	7841837
23.	N.S.	FITTING, Lulu (Part of #22)	
24.	6.242	SEAL, Tie Rod	7840726
25.	6.509	NUT, Hex Slotted (M12 x 1.25 x 13)	14050089
26.	8.938	PIN, Cutter (1/8" x 1 1/2")	
27.	N.S.	BEARING, Pinion Ball (Part of #1)(2)	
28.	N.S.	RING, Retaining (Part of #1)	
29.	8.917	NUT, Hex Lock (M10 x 1.5)	
30.	6.824	COVER, Dust	7828065
31.	6.509	GROMMET, Mounting	7840293
35.	6.674	SEAL, O-Ring, Cyl Line	7828486
37.	6.670	LINE KIT, Cylinder LH (Includes #35)	7841626
38.	6.670	LINE KIT, Cylinder RH (Includes #35)	7841626
40.	N.S.	SEAL, Inner Rack(4)	
41.	6.586	RACK, W/Piston and Nut (Exc FE7)	7840286
	6.586	RACK, W/Piston and Nut (W/FE7)	7841042
42.	N.S.	RING, Piston(4)	
43.	N.S.	BULKHEAD, Cylinder Inner(1)	
44.	N.S.	SEAL, Outer Rack(1,4,5)	
46.	N.S.	SEAL, O Ring(1,4,6)	
46.	N.S.	BULKHEAD, Cylinder Outer(1)	
47.	6.509	RING, Bulkhead Retaining(4,5)	
48.	6.509	CLAMP, Strg Gr to Frame	14048997
49.	8.917	NUT, Hex Prev Torq (M8 x 1.25)(10)	11500760
	8.929	WASHER, Flat (M8 ID 74 OD 23 1hk)	11500323
50.	8.900	BOLT, Hex (M8 x 1.25 x 20)	11508867
51.	6.509	WASHER, Strg Gear Mtg (8 184)	14047879
52.	8.900	BOLT, Hex Hig Hd (M10 x 1.5 x 65)(10,9)	
53.	8.917	NUT, Hex Wa Torq Prev (M10 x 1.5)(10)	

NOTE 1: Part of #7841624 BULKHEAD ASM, Service Kit Grp 6.855.

NOTE 2: Part of #7838728 BEARING KIT, Pinion Grp 6.525.

NOTE 3: Part of #7836278 BEARING KIT, Stub Shaft Grp 6.525

NOTE 4: Part of #7841629 SEAL KIT, Rack and Pinion Grp 6.579.

NOTE 5: Part of #7841623 SEAL KIT, Bulkhead Grp 6.855

NOTE 6: Part of #7841622 SEAL KIT, Pinion and Shaft Grp 6.525.

1Y06-002

1984 "Y" FRONT SUSPENSION

1.	6.168	ARM, Frt Up'r Cont LH (Incl #2, 3, 4, 5, 6)	14067597	35.	8.900	BOLT, Hex (M10 x 1.5 x 60)	
	6.188	ARM, Frt Up'r Cont-RH (Incl #2, 3, 4, 5, 6)	14067598	36.	7.388	INSULATOR, Frt Stab Slf Link Up'r	14076149
2.	6.164	NUT, Strg Knu Up'r Cont Arm	14060153	37.	7.240	LINK, Frt Stab Slf	14048977
3.	6.164	BALL STUD, Strg Knu Up'r Cont Arm	9789596	38.	7.425	BOLT, Frt Spr Het	14078142
4.	6.164	WASHER, Strg Knu Up'r Cont Arm Ball Stud	14047779	39.	7.242	CLAMP, Frt Stab Shf Insl	14048971
5.	8.938	PIN, Cotter (1/8" x 1 1/2")		40.	7.243	INSULATOR, Frt Stab Shf	14060134
6.	6.164	NUT, Strg Knu Up'r Cont Arm Ball Stud (5 418)	14050089	41.	7.242	BRACKET, Frt Stab Shf	14048970
7.	5.002	SHIELD, Frt Brk	14046905	42.	7.241	SHAFT, Frt Stab (Exc H.D. Susp Fb7)	14060132
8.	8.977	SCREW, Hex W/Fl Wu (M8.3 x 1.81 x 18)			7.241	SHAFT, Frt Stab (W/H.D. Susp FE7)	14048992
9.	8.900	BOLT, Hex (M10 x 1.5 x 85)		43.	6.178	WASHER, Frt Up'r Cont Arm	14047733
10.	5.812	BOLT, Frt Whl Mtg	9590476	44.	6.178	SHIM, Frt Up'r Cont Arm (.030 Thk)	14047730
11.	4.665	BOLT, Frt Brk Clip Mtg	14065904	45.	8.917	NUT, Hex Flanged Prev Torq (M10 x 1.5) (Cad 10)	
12.	N.S.	CALIPER, Frt Brk ("1)		46.	N.S.	REINFORCEMENT, Frt Shock Tower ("2)	
13.	5.809	ROTOR, Frt Brk	14055933	47.	8.921	NUT, Spr 'U' Multi Th (M8 x 1.25)	
14.	6.307	HUB, Frt Whl (Incl #10)	7466923	48.	8.900	BOLT, Hex Flg Hd (M10 x 1.5 x 45)	
15.	6.020	KNUCKLE, Strg-LH	14035699	49.	6.178	BOLT, Frt Up'r Cont Arm	14047781
16.	6.178	WASHER, Strg Knu Lwr Cont Arm Ball Stud	14047778	50.	7.003	FRAME, Drivetrain & Frt Susp	14044544
17.	6.164	NUT, Strg Knu Lwr Cont Arm Ball Stud	14048922	51.	7.039	SHIM, Drivetrain & Frt Susp Frnt (1mm as req'd)	14060122
18.	6.174	BALL STUD, Strg Knu Lwr Cont Arm	9769599	52.	N.S.	TOWER, Frt S/Abs ("2)	
19.	6.168	ARM, Frt Lwr Cont LH (Incl #5, 16, 17, 18)	14067623	53.	8.917	NUT, Hex Prev Torq (M10 x 1.5)	
	6.168	ARM, Frt Lwr Cont RH (Incl #5, 16, 17, 18)	14067624	54.	7.389	RETAINER, Frt S/Abs Insl	14044559
20.	8.915	NUT, Hex Flg IM8 x 1.25		55.	7.388	INSULATOR, Frt S/Abs Up'r	14044560
21.	7.010	BOLT, Frt C/Mbr, Hex Flg Hd (M8 x 1.25 x 20) (3 571)	14060613	56.	7.388	INSULATOR, Frt S/Abs Lwr	14044561
22.	7.420	PRO FLOOR, Frt Spr	14048914	57.	7.039	SPACER, Drivetrain & Frt Susp Frnt	14044588
23.	N.S.	PAD, Frt Spr (Part of #26)		58.	7.345	ABSORBER, Frt Shk (Exc H.D. Susp FE7)	4993594
24.	8.915	NUT, Hex (M10 x 1.5)		59.	7.345	ABSORBER, Frt Shk (W/H.D. Susp FE7)	4993596
25.	7.425	RETAINER, Frt Spr	14044557	60.	6.163	NUT, Frt S/Abs Lwr Mtg	14076121
26.	7.412	SPRING, Frt (Exc H.D. Susp FE7) (Incl #23, 27, 28, 29)	14045781	61.	8.917	WASHER, Frt Up'r Cont Arm	14060157
	7.412	SPRING, Frt (W/H.D. Susp FE7) (Incl #23, 27, 28, 29)	14045782	62.	8.508	NUT, Hex Flg Prev Torq (M12 x 1.75)	
27.	N.S.	CUSHION, Frt Spl (Part of #28)		63.	8.508	GEAR, Hyd Strg R & P (Comp) (Exc H.D. Susp FE7) ("3)	7840276
28.	N.S.	BEARING, Frt Spr (Part of #26)			6.508	GEAR, Hyd Strg R & P (Comp) (W/H.D. Susp FE7) ("3)	7841041
29.	N.S.	SEAT, Frt Spl (Part of #26)		63.	8.900	BOLT, Hex Flg Hd (M8 x 1.25 x 50)	
30.	8.900	BOLT, Hex Flg Hd (M8 x 1.25 x 25)		64.	8.917	NUT, Hex Flg Prev Torq (M12 x 1.75)	
31.	7.425	SHIM, Frt Spl Rct	14047771	65.	6.174	WASHER, Frt Lwr Cont Arm (M13 ID 24 OD 3 Thk) (S.383)	14047767
32.	7.380	BRACKET, Frt S/Abs Lwr LH	14048973	66.	6.170	BOLT, Frt Lwr Cont Arm	14049339
33.	7.380	BRACKET, Frt S/Abs Lwr-RH	14048974				
33.	8.900	BOLT, Hex Flg Hd (M8 x 1.25 x 35) (10 9)					
34.	7.388	INSULATOR, Frt Stab Shf Link Lwr	14048975				

NOTE 1. Refer to BRAKE CALIPER illustration in Group 4.000 for detail information.

NOTE 2. Part of MEMBER, Frt, Sides & Cross, Group 7.010

NOTE 3. Refer to HACK & PINION STEERING illustration in Group 6.000 for detail information

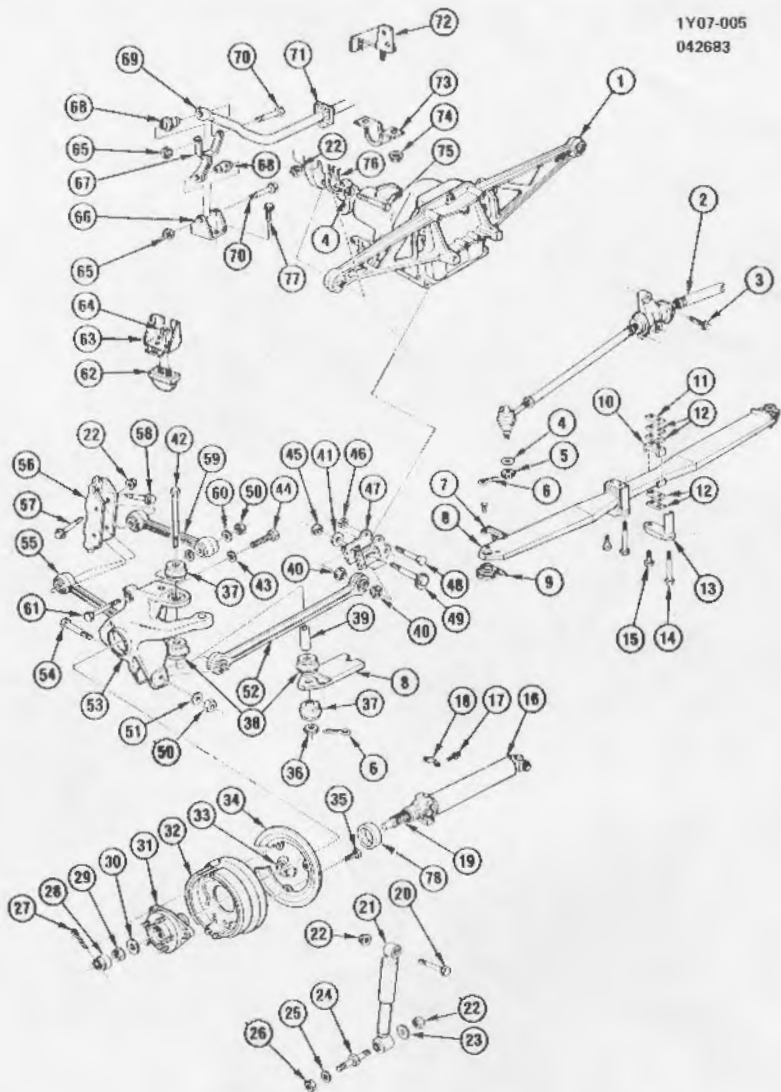
1Y07-005
042693

1Y07.005

Figure 35 — 1984 "Y" REAR SUSPENSION

1Y07-005

1984 "Y" REAR SUSPENSION

1.	5.505	CARRIER, Diff (Cont'd) (See Catalog) (*)		39.	7.535	SPACER, Rr Spr Inst (W/H D Snap F E 7 only)	14060140
2.	5.415	ROD, Rr Axle Tie	14060139	40.	6.170	BUSHING, Rr Whl Spdl Rod	14060166
3.	5.416	BOLT, Rr Axle Tie (7.425)	14076142	41.	6.172	CAM, Rr Whl Spdl Rod Adj	14060163
4.	5.418	WASHER, Rr Axle Tie Rod to 16 I	14047779	42.	7.529	BOLT, Rr Spr	14044578
5.	5.418	NUT, Rr Axle Tie Rod	14050089	43.	5.383	WASHER, Driveline Spr IM 13 to 24 OD 3 Thk.	14047787
6.	8.938	PIN, Center (M 2 x 2b)		44.	5.812	BOLT, Rr Whl Hub	14046943
7.	N.S.	RETAINER, Rr Spr Upr (Part of 4d)		45.	5.415	NUT, Rr Whl Spdl Rod Adj	14060164
8.	7.503	SPRING, Rr (Exc H D) Susp IE7 (Incl # 7, 9, 10)	14045785	46.	8.917	NUT, Hex Flgd Prev Torq (M 10 x 1.5)	
	7.503	SPRING, Rr (W/H D) Susp IE7 (Incl # 7, 9, 10)	14045786	47.	5.380	BRACKET, Rr Whl Spdl Rod	14060165
9.	N.S.	RETAINER, Rr Spr Lwr (Part of 4b)		48.	8.900	BOLT, Hex Flg Hd (M 10 x 1.5 x 7b)	
10.	N.S.	CUSHION, Rr Spr (Part of 4d)		49.	5.806	BOLT, Rr Whl Spdl Rod Adj	14060162
11.	7.545	INSULATOR, Rr Spr	14044575	50.	8.915	NUT, Hex (M 16 x 2)	
12.	7.518	SPACER, Rr Spr (Exc H D Susp FE 7)	14046950	51.	5.415	WASHER, Rr Whl Spdl Rod	14047726
	7.518	SPACER, Rr Spr (W/H D Susp FE 7)	14044572	52.	5.415	ROD, Rr Whl Spdl RH	14048947
13.	7.518	PLATE, Rr Spr Adj	14048993	53.	5.380	ROD, Rr Whl Spdl RH	14048948
14.	8.500	BOLT, Hex Flgd Hd (M 10 x 1.5 x 10f)		54.	5.380	KNUCKLE, Rr Susp RH	14041901
15.	8.900	BOLT, Hex Flgd Hd (M 10 x 1.5 x 3D)		55.	8.900	BOLT, Hex (M 16 x 2 x 110)	14041902
16.	5.420	SHAFT, Rr Whl Dr Ujt (W/A T, Exc 6 Way Seat)	14046912	56.	5.415	ROD, Rr Whl Spdl Lwr Cont	14048931
	5.420	SHAFT, Rr Whl Dr Ujt (W/M T) (W/A T & 6 Way Seat)	14041926	57.	5.418	BRACKET, Rr Whl Spdl Cont Rod	14071742
	5.425	REPAIR KIT, Ujt, Rr Whl Dr Shk	14067677	58.	8.900	BOLT, Hex Flgd Hd (M 12 x 1.75 x 5U)	14048989
17.	5.588	BOLT, Rr Whl Dr Ujt Shf Ret	14046904	59.	5.415	ROD, Rr Whl Spdl Upr Cont	14048930
18.	5.588	RETAINER, Rr Whl Dr Ujt Shf	14046907	60.	5.415	WASHER, Rr Whl Spdl Rod to Knu	14044574
19.	5.808	SPINDLE, Rr Whl	14055941	61.	5.418	BOLT, Rr Whl Spdl Rod to Knu	14048990
20.	7.347	BOLT, Rr S/Ans Upr (5.418)	14046989	62.	7.535	BUMPER, Rr Susp Jounce	14044577
21.	7.345	ABSORBER, Rr Shk (Exc H D Shk)	4993595	63.	7.535	BRACKET, Rr Susp Jounce Bpr	14064511
	7.345	ABSORBER, Rr Shk (W/H D Shk)	4993597	64.	8.915	NUT, Hex (M 10 x 1.5)	
22.	8.917	NUT, Hex Flgd (M 12 x 1.75)		65.	7.245	NUT, Rr Stab Shf Link	14060131
23.	7.347	WASHER, Rr S Abs	14047726	66.	7.242	SHACKLE, Rr Stab Shf	14080115
24.	7.347	STUD, Rr S/Abs	14044582	67.	7.240	LINK, Rr Stab Shf	14060113
25.	7.347	WASHER, Rr S/Abs (5.383)	10019448	68.	7.243	INSULATOR, Rr Stab Shf Link	14060114
26.	8.917	NUT, Hex Prev Torq (M 14 x 2)		69.	7.241	SHAFT, Rr Stab (Exc H D Susp FE 7)	14060109
27.	8.938	PIN, Center (M 4 x 40)		70.	7.240	BOLT, Rr Stab Shf Link	14060130
28.	5.806	CAP, Rr Whl Spdl Nut (6.056)	562248	71.	7.243	INSULATOR, Rr Stab Shf (Exc H D Susp FE 7)	14080111
29.	5.806	NUT, Rr Whl Spdl	562247	72.	7.241	INSULATOR, Rr Stab Shf (W/H D Susp FE 7)	14060112
30.	5.806	WASHER, Rr Whl Spdl (6.056)	562249	73.	7.242	SUPPORT, Rr Stab Shf Brkt LH	14084521
31.	5.806	HUB, Rr Whl	7466924	74.	7.242	SUPPORT, Rr Stab Shf Brkt RH	14064522
	5.812	BOLT, Rr Whl Mtg	9590470	75.	8.915	BRACKET, Rr Stab Shf	3913863
32.	N.S.	PLATE ASM, Rr Park Brk & Clp Mtg (*)		76.	5.506	NUT, Hex Flg (M 8 x 1.25)	14080116
33.	5.806	WASHER, Rr Whl Spdl	14076924		N.S.	BRACKET, Diff Carr (Part of MEMBER, Rr S/Group 7.006)	
34.	5.002	SHIELD, Rr Brk LH	14055965	77.	8.900	BOLT, Hex (M 8 x 1.25 x 30)	14046941
	5.002	SHIELD, Rr Brk RH	14055966	78.	5.822	SEAL, Rr Whl Hub Big	
35.	8.917	SCREW, Hex Flg Wa Top (M 3 x 1.81 x 1b)					
36.	7.530	NUT, Rr Spr (6.164)	14048922				
37.	7.545	INSULATOR, Rr Spr	14044580				
38.	7.545	INSULATOR, Rr Spr (This location only required W/H D Susp FE 7)	14044580				

NOTE 1: CARRIER DIFFERENTIAL details shown in Group 5 (4.00) illustration

NOTE 2: Refer to PARK BRAKE illustration in Group 4 (3.00) for details

V7-21

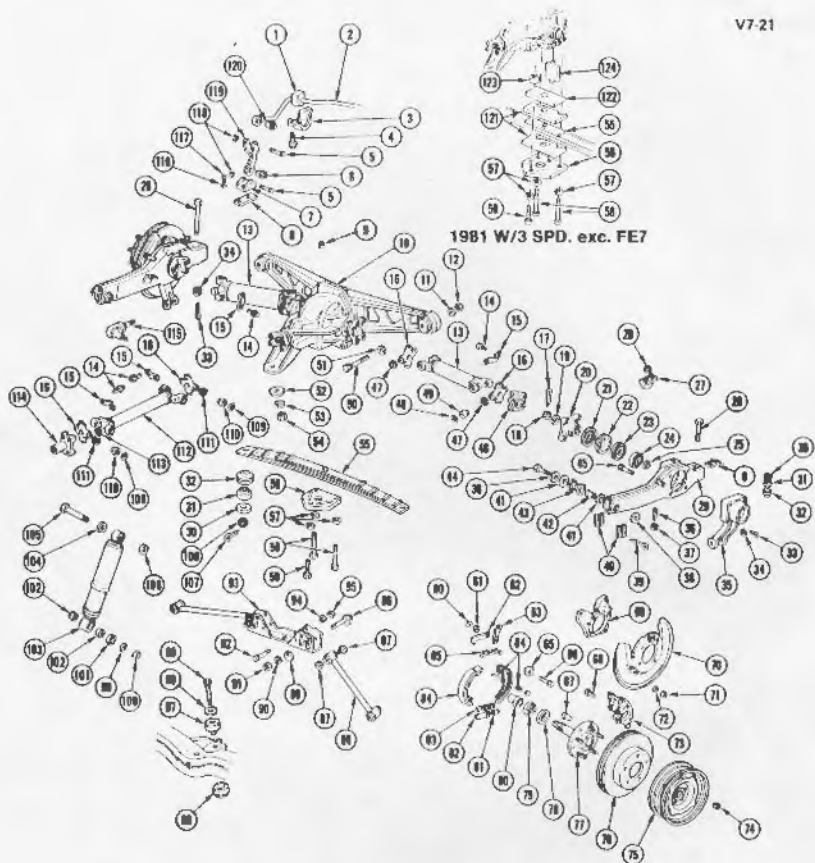

V7-21

Figure 36 — 1980-82 "Y" REAR SUSPENSION

V7-21

1980-82 'Y' REAR SUSPENSION

1.	BUSHING, Rr Stub Shaft	7 243	62.	STRUT, Parking Brake Shoe Lever	5 150
2.	SHAFT, Rr Stub	7 241	63.	LEVER, Parking Brake Shoe	5 149
3.	BRACKET, Rr Stub Shaft	7 242	64.	PIN KIT, Brake Shoe	5 043
4.	SCREW, Rr Stub Shaft Brkt	7 242	65.	PLATE, Brake Shoe Guide	5 046
5.	BOLT [3/8" - 16 x 1 3/8"]	8 900	66.	BOLT, Hex [7/16" - 20 x 1 1/16"]	5 066
6.	BUSHING, Rr Stub Shaft Link	7 243	67.	RIVET, Spindle	N.S.
7.	BRACKET, Rr Stub Shaft Link	7 242	68.	BOLT, Hex [7/16" - 20 x 1 1/8"]	8 900
8.	PLATE, Rr Stub Shaft Link	7 245	69.	BRACKET, Brake Flange Rr	5 001
9.	PLUG, W. Instruction Tag [1 7/64" OD]	5 400	70.	PLATE, Parking Brake	5 001
10.	CARRIER, Diff W. Cap	5 605	71.	NUT, Hex [3/8" - 24]	8 915
11.	WASHER, Lock	8 931	72.	WASHER [3/8"]	8 931
12.	NUT, Hex	8 900	73.	HOUSING ASM, Brake Caliper	4 665
13.	SHAFT, Axle	6 420	74.	NUT, Whit [7/16" - 20]	5 813
14.	BOLT, Hex [7/16" - 20 x 1 1/8"]	8 900	75.	WHEEL ASM	5 803
15.	RETAINER, Prop & Axle Shift U-Joint (5.428)	5 380	76.	DISC, Rr Whl (brake)	5 809
16.	REPAIR KIT, U Joint	5 548	77.	SPINDLE, Rr Whl	5 806
17.	PIN, Rr Whl Spindle	8 938	78.	SEAL, Rr Whl Otr Brg	5 822
18.	NUT, Hex Slot [3/4" - 20]	5 829	79.	BEARING ASM, Rr Whl Otr	5 855
19.	WASHER [7/32"]	5 830	80.	SPACER, Bearing	5 816
20.	FLANGE, Rr Whl Spindle	5 808	81.	SOCKET, Air Screw	5 111
21.	DEFLECTOR, Rr Whl Spindle	5 425	82.	SCREW, W Nut, Parking Brake Adj	5 110
22.	SHIELD, Rr Whl Inr Bearing	5 815	83.	SPRING, Parking Brake	5 026
23.	SEAL, Rr Inr Bearing	5 822	84.	SHOE KIT, Parking Brake	5 017
24.	BEARING, Rr Whl Inr	5 855	85.	SPRING, Parking Brake	5 026
25.	SHIM, Rr Wheel	5 855	86.	CAM, Spindle Support Strut	5 417
26.	NUT, Hex [3/8" - 16]	8 917	87.	CAP, Rr Whl Strut Rod Bushing	5 417
27.	BUMPER, Rr Spring	7 535	88.	ROD, Rr Whl Strut ("1)	5 415
28.	BOLT, Rr Spring	7 529	89.	CAM, Rr Whl Strut	5 417
29.	ARM, Torque Control	5 382	90.	WASHER, Lock [1/2"]	8 931
30.	RETAINER, Spring Otr	7 545	91.	NUT, Hex [1/2" - 20]	8 921
31.	CUSHION, Rr Spring	7 545	92.	BOLT, Hex [M10 x 1.5 x 70]	8 900
32.	RETAINER, Spring Inr	7 545	93.	BRACKET, Rr Whl Strut	5 380
33.	PIN, Cotter	8 938	94.	WASHER, Lock	8 931
34.	NUT, Hex Slot [5/8" - 18]	8 917	95.	NUT, Hex [M10 x 1.5 x 70]	8 916
35.	SUPPORT, Control Arm to Spindle	5 380	96.	INSULATOR, Diff Carrier Mt Lwr	8 023
36.	PIN, Cotter	8 938	97.	INSULATOR, Diff Carrier Mt Upr	8 023
37.	NUT, Diff Carrier Mount (Hex Slot, 7/16" - 20)	8 000	98.	WASHER [1 1/32" x 1 1/8 x 1/8]	8 929
38.	WASHER, Torque Control Arm	5 383	99.	BOLT, Hex [7/16" - 14 x 3 1/8"]	8 900
39.	PIN, Cotter	8 938	100.	NUT, Shock Abs Lwr [1/2" - 20]	5 383
40.	SHIM, Rr Axle Torque Arm	5 380	101.	RETAINER, Lwr Grommet Otr	7 389
41.	PLATE, Rr Susp Torque	5 381	102.	GROMMET, Shock Abs Lwr	7 388
42.	RETAINER, Torque Arm Bushing	5 381	103.	ABSORBER, Rr Shock	7 346
43.	BUSHING, Upr Rr	5 381	104.	WASHER, Lock	8 931
44.	BOLT, Torque Control Arm	5 383	105.	BOLT, Shock Abs Upr	7 374
45.	BOLT, Hex [3/8" - 24 x 2 7/8"]	5 002	106.	NUT [7/16" - 20]	8 916
46.	FLANGE, Rr Whl U Joint	5 425	107.	PIN, Cotter	8 938
47.	SEAL, Yoke Bearing (Also Part of # 16)	5 430	108.	NUT, Hex Slot [9/16" - 18]	8 917
48.	LOCK RING, U Joint (Also Part of # 16)	5 586	109.	LOCK RING, U Joint (Also Part of # 16)	5 586
49.	BEARING, U Joint (Also Part of # 16)	5 428	110.	BEARING, U Joint (Part of # 16)	5 548
50.	BOLT, Hex	8 900	111.	SEAL, U-Joint (Also Part of # 16)	5 560
51.	WASHER	8 929	112.	SHAFT, Propeller	5 644
52.	PLATE, Body Mtg Cushion	N.S.	113.	SPACER, Transm Bearing	5 586
53.	WASHER, Lock [7/16"]	8 931	114.	YOKE, U-Joint Sleeve Frt	5 655
54.	NUT, Hex [7/16" - 14]	8 916	115.	SHAFT, Rr Whl Spindle Rod	5 381
55.	SPRING, Rear	7 593	116.	WASHER, Lock	8 931
56.	PLATE, Rr Spring	7 518	117.	BOLT [5/16" - 18 x 3/4"]	8 900
57.	WASHER, Lock [7/16"]	8 941	118.	NUT, Hex [3/8" - 16]	8 915
58.	BOLT, Hex [M12 x 1.75 x 90] [10 8 Pt.]	8 900	119.	LINK, Rr Stub Shaft	7 240
59.	BOLT, Hex [M12 x 1.75 x 30]	8 900	120.	BUSHING, Rr Stub Shaft Link	7 243
60.	CLIP, Parking Lever	5 056	121.	SPACER, Rr Spr	7 518
61.	WASHER, Pivot pin	5 158	122.	INSULATOR, Hr Spr	7 546
			123.	SPACER, Rr Spr [1/2" ID 1 1/8" OD] 3/16 Thick	7 518
			124.	SPACER, Rr Spr Plate to Diff	7 518