

REESE

INSTALLATION INSTRUCTIONS CHEVROLET CORVETTE

Product No.

89072

You *can* take it with you.

ELKHART, IN., OAKVILLE, ONT.

SMALL PARTS
PACKAGE 89429

WARNING: DO NOT LUBRICATE THREADS, BOLT FAILURE MAY OCCUR DUE TO OVER TIGHTENING.
WARNING: DO NOT DRILL OR WELD TO THIS HITCH.

IMPORTANT NOTES
USE ONLY REESE SUPPLIED OR APPROVED BOLTS, LOCKNUTS, AND WASHERS TO INSTALL THIS HITCH.

TOOLS REQUIRED

3/4"	SOCKET
3/4"	WRENCH
9/16"	SOCKET
7/16"	DRILL BIT
1/2" X 8" LONG	DRILL BIT
1/2"	DRIVE DRILL MOTOR
	TORQUE WRENCH

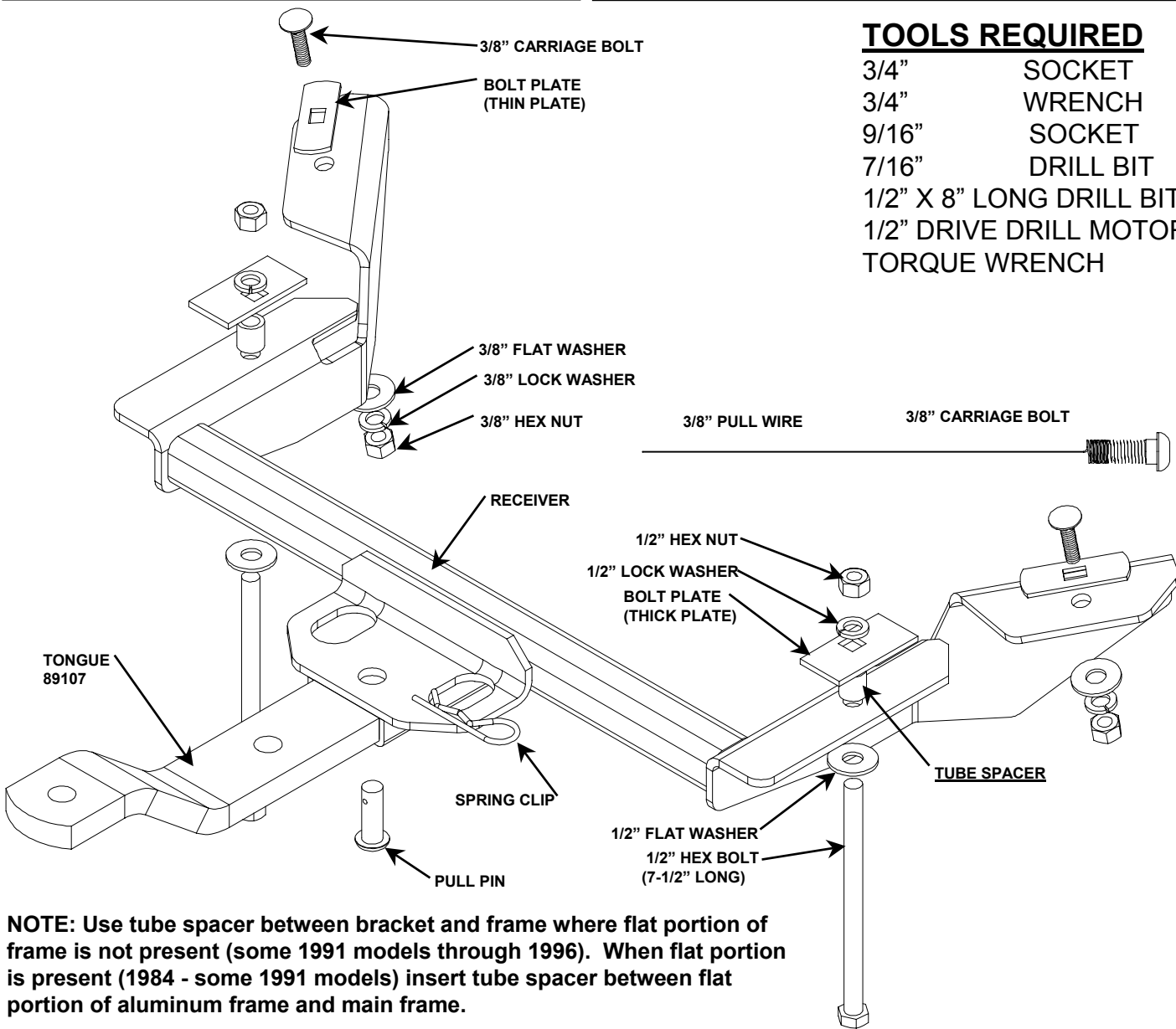

NOTE: Use tube spacer between bracket and frame where flat portion of frame is not present (some 1991 models through 1996). When flat portion is present (1984 - some 1991 models) insert tube spacer between flat portion of aluminum frame and main frame.

1. Lower spare tire carrier.
2. With a flat screwdriver - bend tabs down with which fuel tank straps are attached, in order to gain access into frame.

(OVER)

For Installation Assistance or Technical Help, Call 1-800-758-0869

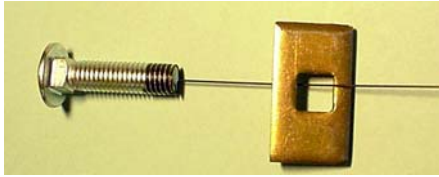

FIG 1

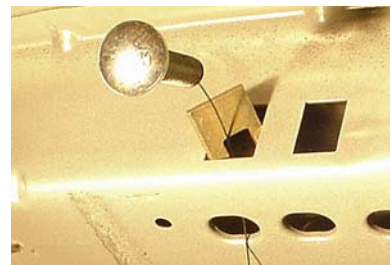

FIG 2 EXAMPLE: SEE NOTE 5

3. Hold receiver up to frame - center and move as far rearward as valance will allow - mark holes for drilling.
4. Drill 7/16" diameter holes in frame at forward marks. Drill 1/2" diameter holes in frame at rear marks. For rear holes, you must align drill bit so it will extend thru frame just forward of welds at end of frame.
5. Insert pull wire up thru forward drilled hole on frame and out thru access hole - thread 3/8" carriage bolt with bolt plate onto 3/8" pull wire (Fig 1) - feed bolt plate into frame (Fig 2) then pull 3/8" carriage bolt into place - repeat for opposite side.
6. Place receiver up to frame, being careful not to push carriage bolts into frame - once bolts are thru flanges on receiver apply 3/8" flat washers, 3/8" lock washers, and 3/8" hex nuts finger tight.
7. Place 1/2" flat washer on 1/2" x 7-1/2 long bolts and insert thru frame bracket, tube spacer, and 1/2" drilled holes at rear of frame.

NOTE:

 - 84-91: Place tube spacer between flat portion of frame and main frame.
 - 91-96: Place tube spacer between receiver bracket and frame.

Apply thick bolt plate and 1/2" lock washer and 1/2" hex nut.
8. Torque 3/8" hardware to 35 lb-ft.
Torque 1/2" hardware to 75 lb-ft.

For Installation Assistance or Technical Help, Call 1-800-758-0869

THIS PRODUCT COMPLIES WITH SAFETY SPECIFICATION AND REQUIREMENTS FOR THE STATE OF NEW YORK AND VESC REGULATION V-5 FOR CONNECTING DEVICES AND TOWING SYSTEMS. WEIGHT CARRYING HITCH RATING IS 3500 LB MAX GROSS TRAILER WEIGHT AND 350 LB MAX TONGUE WEIGHT. CONSULT VEHICLE OWNERS MANUAL FOR TOWING RECOMMENDATIONS AND LIMITATIONS.

LIMITED WARRANTY

Reese warrants its Hitches, custom Hitch Receivers, and Sway Controls from date of purchase against defects in material and workmanship under normal use and service, ordinary wear and excepted, for the ownership life of the original consumer purchaser. Reese will replace FREE OF CHARGE any part which proves defective in material or workmanship when presented to any Reese dealer, Reese Warehouse or return to factory. TRANSPORTATION CHARGES PREPAID, at the address below. THIS WARRANTY IS LIMITED TO DEFECTIVE PARTS REPLACEMENT ONLY. LABOR CHARGES AND/OR DAMAGE INCURRED IN INSTALLATION OR REPLACEMENT AS WELL AS INCIDENTAL AND CONSEQUENTIAL DAMAGES CONNECTED THEREWITH ARE EXCLUDED. Some states do not allow the exclusion or limitation of incidental or consequential damages, so the above limitation or exclusion may not apply to you. Any damage to the Hitch, Custom Hitch receiver or Sway Control as a result of misuse, abuse, neglect, accident, improper installation, or any use violative of instructions furnished by us, WILL VOID THE WARRANTY. This warranty gives you specific legal rights, and you may also have other rights which vary from state to state. In the event of a problem Reese warrants its Hitches, Custom Hitch Receivers and Sway Controls from date of purchase against defects in material and workmanship under normal use and service, ordinary wear and tear excepted, for the ownership life of the original consumer purchaser. with warranty service or performance, you may be able to go to a small claims court, a state court, or a federal district court.

Reese Products, Inc.
51671 State Road 19-N
Elkhart, IN 46514

Reese Products of Canada, Ltd.
475 Wycroft Road
Oakville, Ontario
Canada L6K2H2