

High Volume LS Series Engine Oil Pump Kit

PN: L200315297

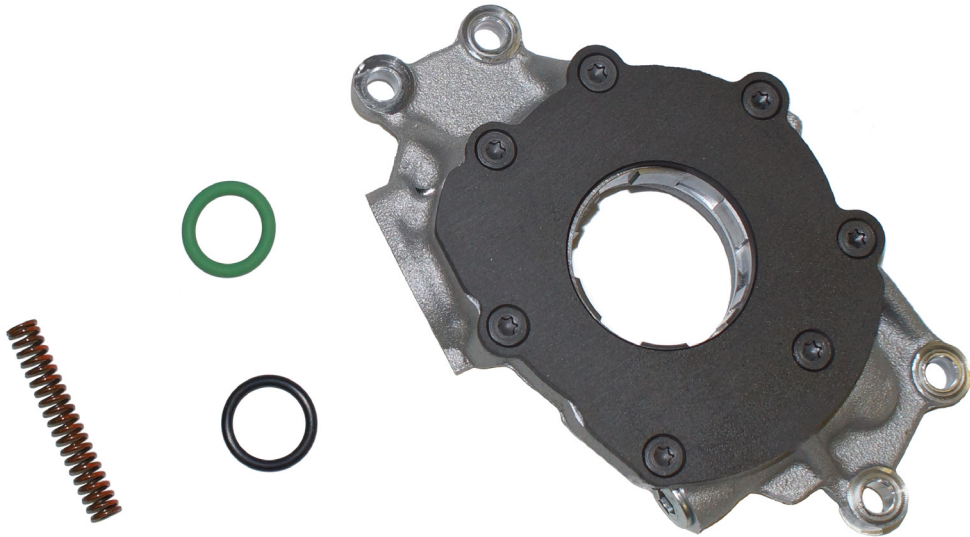

Parts List

#	Description
1	High volume Gen III/IV GM V8 oil pump with standard pressure spring
1	High pressure spring, orange
1	Pickup tube O-ring, black
1	Pickup tube O-ring, green
1	LPE decal

Pump specifications:

- Over 30% higher volume capacity pump than the stock LS1/LS6/LS2/LS3 oil pump
- Displacement of 1.26 in³/rev
 - The stock LS1/LS6/LS2/LS3 pump is 0.95 in³/rev
- 8/9 gear set with a 12.9mm thick gear
 - The stock LS1/LS6/LS2/LS3 pump gear is 10.7mm thick
- Includes standard and high pressure PRV springs
- Includes both car and truck pickup tube O-rings
- Fits factory timing cover
 - **NOTE:** This high volume oil pump is thicker than the production LS1, LS6, LS2 and LS3 oil pump and may not fit in a stock timing cover with aftermarket double roller timing chains that require spacing out the oil pump.

The Lingenfelter Performance Engineering (LPE) high volume GM Gen III & IV V8 oil pump is recommended for use in applications that will require increased pump flow to achieve the desired oil pressure. Engines with piston oil cooling jets, radiused crank bearings, aftermarket lifters or increased build clearances may require a higher volume pump to achieve the same oil pressure, especially at low engine speeds and higher oil temperatures when the pressure relief valve (PRV) is not in control of oil pressure.

This oil pump is supplied with a standard pressure relief spring installed in the pump's pressure relief valve. This spring is yellow in color. For most applications this is the spring that LPE recommends you use. For cylinder deactivation equipped engines you will want to use the higher pressure relief spring. If a higher oil pressure is desired, remove the yellow spring and replace it with the supplied orange spring. The orange spring will provide a roughly 10 psi increase in peak oil pressure. With the installed standard pressure yellow spring, the pressure relief valve should start to open at 33 psi and be in full relief at 65 psi while with the high pressure orange spring the relief valve should start to open at 43 psi and will be in full relief by 75 psi.

Torque the pressure relief valve plug to 12 Nm (106 inch-lbs) with an 8 mm (or 5/16") Allen socket.

NOTE: Changing the relief spring will not change the low RPM idle pressure.

Oil pickup tube O-ring:

Two different pickup tube O-rings designs exist. Figure 1 usually applies to truck applications and Figure 2 usually applies to car applications. If the end of the pickup tube that installs into the oil pump looks like either design in Figure 1, use the supplied green O-ring (the stock O-ring should be green or red in this application). If the end of the pickup tube that installs into the oil pump looks like what is shown in Figure 2, use the black O-ring (the stock O-ring in this application should be light blue).

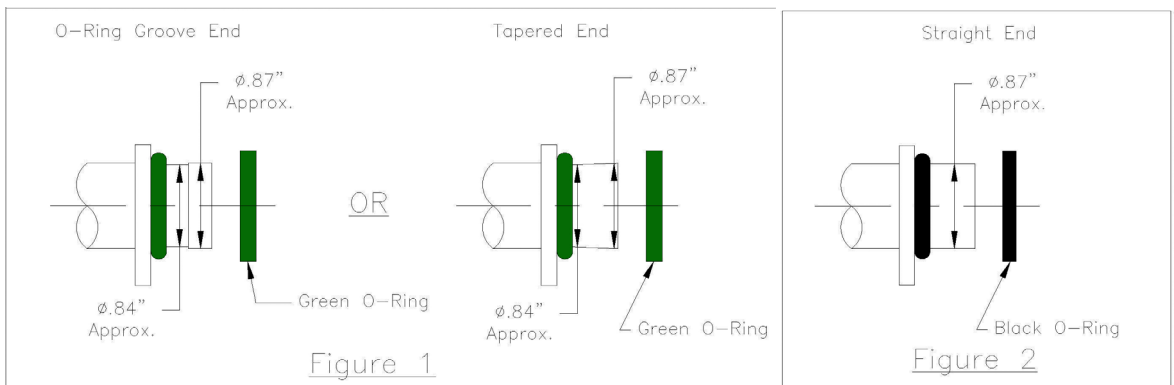

Lingenfelter Performance Engineering
1557 Winchester Road
Decatur, Indiana 46733
(260) 724-2552 phone
(260) 724-8761 fax
www.lingenfelter.com