

<- Back

Forward ->

Document ID# 595265
1999 Chevrolet/Geo Corvette

Print

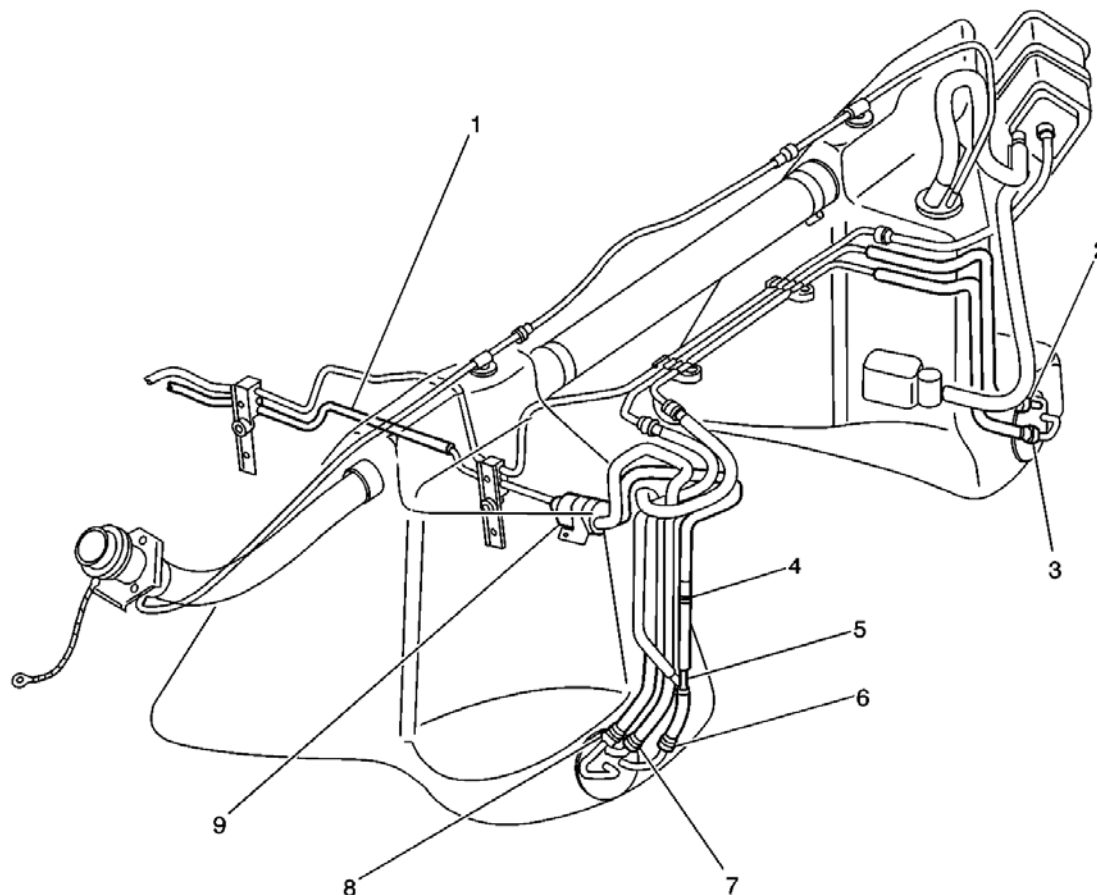

- (1) Fuel Feed Pipe
- (2) Auxiliary Fuel Feed Rear Pipe (left tank to jet pump)
- (3) Auxiliary Fuel Return Rear Pipe (jet pump to left tank)
- (4) Fuel Feed Pipe Check Valve
- (5) Fuel Feed Pipe Tee with Orifice
- (6) Fuel Feed Rear Pipe (to fuel filter/fuel pressure regulator and siphon jet pump)
- (7) Fuel Return Rear Pipe
- (8) Auxiliary Fuel Return Rear Pipe (jet pump to left tank)
- (9) Fuel Filter/Fuel Pressure Regulator

<- Back

Forward ->

Document ID# 595265
1999 Chevrolet/Geo Corvette

Print

Fuel Sender Assembly Replacement

[Removal Procedure \(Left or Right\)](#)

Tools Required

- [J 34730-1A](#) Fuel Pressure Gauge
- [J 37088-A](#) Tool Set, Fuel Line Quick Connect Separator

Caution

Before servicing any electrical component, the ignition key must be in the OFF or LOCK position and all electrical loads must be OFF, unless instructed otherwise in these procedures. If a tool or equipment could easily come in contact with a live exposed electrical terminal, also disconnect the negative battery cable. Failure to follow these precautions may cause personal injury and/or damage to the vehicle or its components.

1. Disconnect the negative battery cable.
2. Relieve the fuel system pressure. Refer to the [Fuel Pressure Relief Procedure](#) .
3. Raise the vehicle. Refer to [Lifting and Jacking the Vehicle](#) in General Information.
4. Remove the rear wheel and tire assembly. Refer to [Tire and Wheel Removal and Installation](#) in Tires and Wheels.
5. Clean all of the fuel connections and the surrounding areas before disconnecting the fuel pipes in order to avoid possible contamination of the fuel system.
6. Drain the fuel tanks. Refer to [Fuel Tank Draining Procedure](#) .
7. Remove the fuel tank shield.
8. Mark or identify each fuel pipe in order to aid in installing the pipes in their original positions.
9. Disconnect the quick-connect fittings from the fuel sender. Refer to [Quick Connect Fitting\(s\) Service \(Metal Collar\)](#) or [Quick Connect Fitting\(s\) Service \(Plastic Collar\)](#) .
10. Cap all of the fuel pipes.
11. Disconnect the fuel sender electrical connector.
12. Remove the fuel tank strap.
13. Support the fuel tank.
14. Remove the fuel sender attaching bolts. Remove previously installed "break-away head" service bolts using a 5/16 inch open end wrench.
15. Discard the fuel sender attaching bolts.
16. Remove the float arm retaining clip and the float arm (left fuel sender only).
17. Carefully remove the fuel sender with the gasket.
18. Discard the fuel sender gasket.
19. Clean the gasket sealing surfaces.

[Installation Procedure \(Right\)](#)

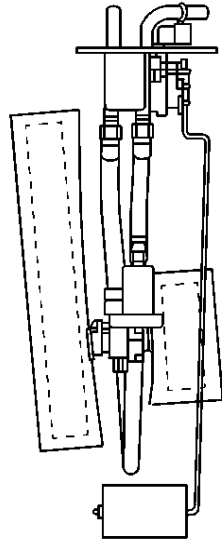

Caution

In order to reduce the risk of fire and personal injury that may result from a fuel leak, always replace the fuel sender gasket and the fuel sender attaching bolts when reinstalling the fuel sender assembly.

1. Install a new fuel sender gasket on the fuel sender.
2. Fold the long strainer in half over itself and hold the strainer in this position.
3. Pinch both strainers upward toward each other.

Important

Do not bend or twist the float arm.

4. Insert the float arm through the fuel tank opening followed by the folded strainers.
5. Release the strainers once the strainers are in the fuel tank. The strainers will spring back to their full position.
6. Continue inserting the fuel sender through the fuel tank opening. It may be necessary to rotate the fuel sender in order to facilitate the installation.
 - A. Look through the fuel tank opening to ensure that the long strainer is visible.
 - B. If the strainer is not visible, rotate the fuel sender clockwise and counterclockwise about 90 degrees. Rotating the fuel sender will free up the strainer. The strainer should become visible at the tank opening.

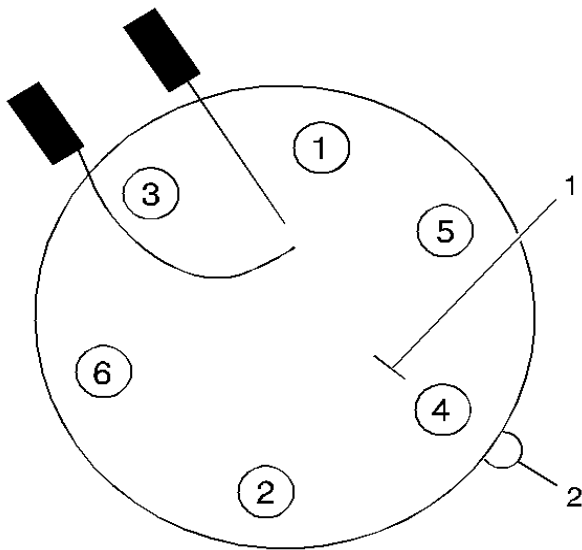

7. Align the fuel sender gasket tab (2) with the fuel sender cover mark (1).
8. Align the fuel sender cover mark (1) with the fuel tank mark.

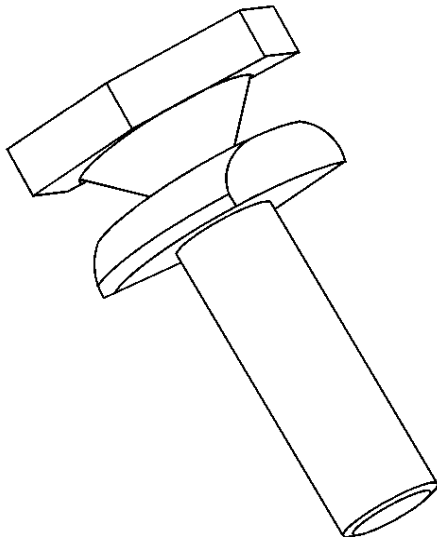

Notice

Use the correct fastener in the correct location. Replacement fasteners must be the correct part number for that application. Fasteners requiring replacement or fasteners requiring the use of thread locking compound or sealant are identified in the service procedure. Do not use paints, lubricants, or corrosion inhibitors on fasteners or fastener joint surfaces unless specified. These coatings affect fastener torque and joint clamping force and may damage the fastener. Use the correct tightening sequence and specifications when installing fasteners in order to avoid damage to parts and systems.

9. Hand tighten the new "break-away head" fuel sender attaching bolts until finger tight.

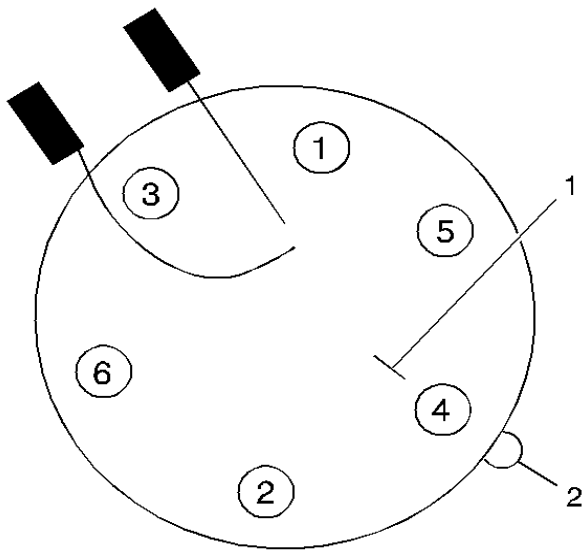

Important

The upper hex head portion of the fuel sender attaching bolts is designed to shear off of the lower section of the bolt when the proper torque is reached. Do not tighten the bolts after the bolt heads have sheared off. A torque wrench or other special tool(s) are not required. Do not use thread locking or other types of sealers or lubricants when installing these bolts and gasket.

10. Tighten the new "break-away head" fuel sender assembly attaching bolts in sequence until the upper hex head portion of the bolts shear off of the lower section.

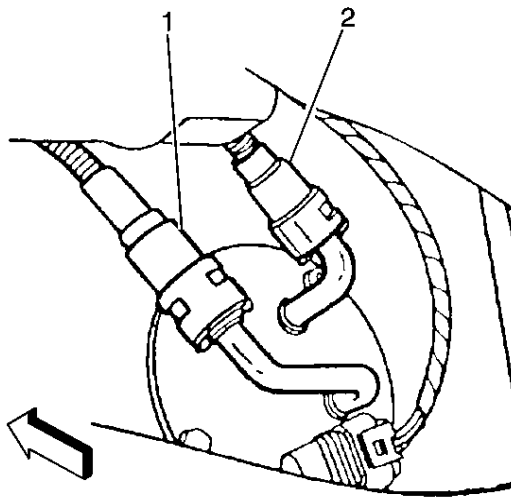

11. Connect the fuel sender fuel feed pipe (1) (jet pump to left tank) and the fuel feed rear crossover pipe (2) (left tank to jet pump). Refer to [Quick Connect Fitting\(s\) Service \(Metal Collar\)](#) or [Quick Connect Fitting\(s\) Service \(Plastic Collar\)](#).
12. Connect the fuel sender electrical connector.

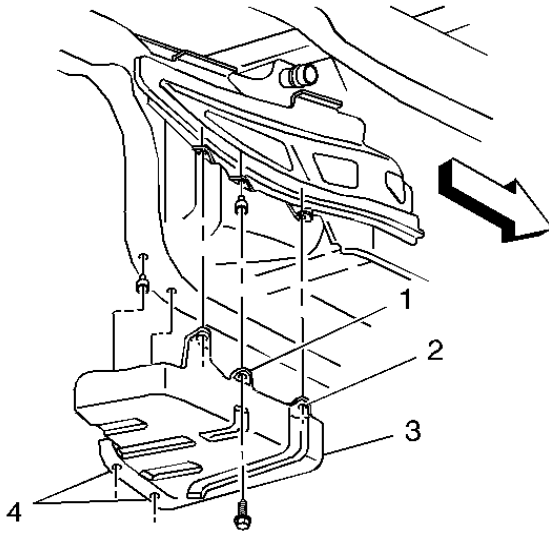

13. Install the fuel tank strap (3).
14. Install the fuel tank strap bolts (1, 2, 4). **Tighten**
 - a. Tighten bolt (2) to 25 N·m (18 lb ft).
 - b. Tighten bolt (1) to 25 N·m (18 lb ft).
 - c. Tighten the remaining bolts (4) to 25 N·m (18 lb ft).

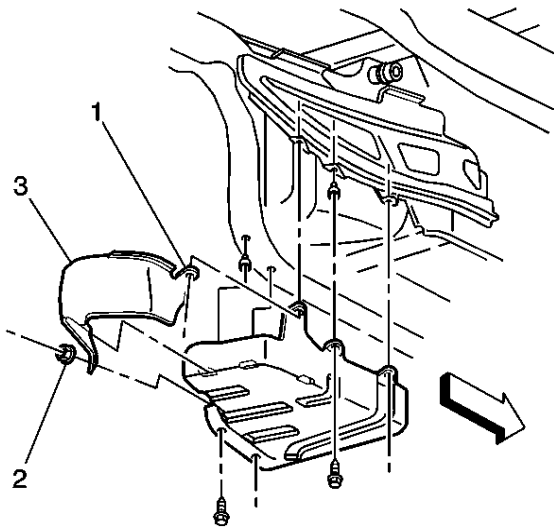

15. Install the fuel tank shield (3).
16. Install the fuel tank shield mount bolt (1).
17. Install the fuel tank shield mount nut (2). **Tighten**
 - o Tighten the fuel tank shield mount bolt to 25 N·m (18 lb ft).
 - o Tighten the fuel tank shield mount nut to 25 N·m (18 lb ft).
18. Install the rear wheel and tire assembly. Refer to [Tire and Wheel Removal and Installation](#) in Tires and Wheels.
19. Lower the vehicle.
20. Refill the fuel system.
21. Install the fuel filler cap.
22. Connect the negative battery cable.

23. Inspect for leaks.
 - A. Turn the ignition switch ON for 2 seconds.
 - B. Turn the ignition switch OFF for 10 seconds.
 - C. Turn the ignition switch ON.
 - D. Check for fuel leaks.
24. Program the transmitters. Refer to [Transmitter Programming/Synchronization](#) in Keyless Entry.
25. Perform the idle learn procedure. Refer to *PCM Idle Learn Procedure* .

[Installation Procedure \(Left\)](#)

Important

Always install a new fuel pump strainer before reinstalling the left fuel sender assembly. A fuel pump strainer that has been exposed to fuel will not unfold in the fuel tank and may block full travel of the float arm.

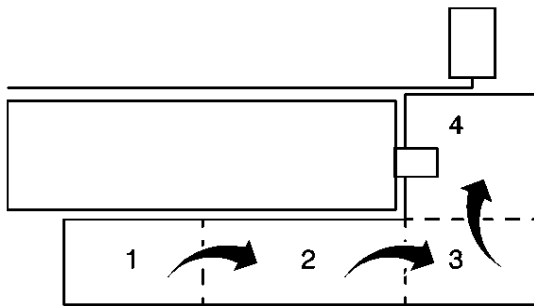

1. Install a new fuel pump strainer in the same position as noted during disassembly. Push on the outer edge of the strainer ferrule until the strainer is fully seated.

Caution

In order to reduce the risk of fire and personal injury that may result from a fuel leak, always replace the fuel sender gasket and the fuel sender attaching bolts when reinstalling the fuel sender assembly.

2. Install a new fuel sender gasket on the fuel sender.
3. Fold the strainer three times so that the amount of space occupied by the strainer is about equivalent to the diameter of the fuel sender reservoir.
 - A. Fold the long side of the strainer over (1 over 2).
 - B. Fold 3 over 4 and hold the strainer in the folded position.
4. Insert the fuel sender through the fuel tank opening.
5. Release the strainer once the strainer is in the fuel tank. The strainer will spring back to its full position.
6. Continue inserting the fuel sender through the fuel tank opening. It may be necessary to rotate the fuel sender in order to facilitate the installation.

- A. Look through the fuel tank opening to ensure that the long side of the strainer is visible.
- B. If the strainer is not visible, rotate the fuel sender clockwise and counterclockwise about 90 degrees. Rotating the fuel sender will free up the strainer. The strainer should become visible at the tank opening.

Important

Do not bend or twist the float arm.

7. Insert the float and the float arm into the fuel tank opening.
8. Install the float arm retaining clip.

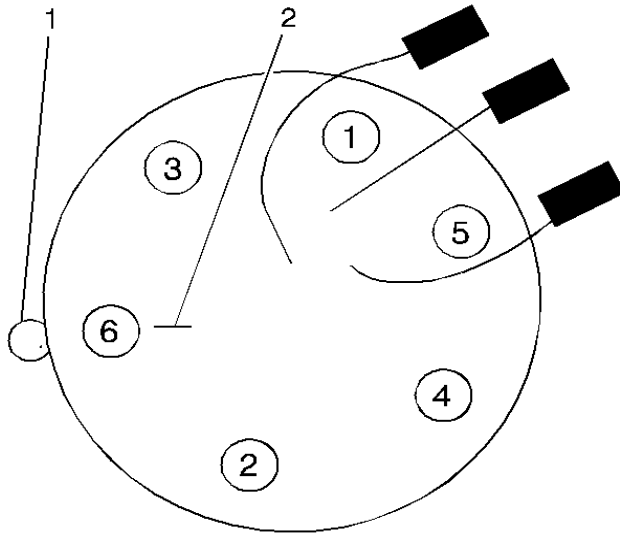

9. Align the fuel sender gasket tab (1) with the fuel sender cover mark (2).
10. Align the fuel sender cover mark (2) with the fuel tank mark.

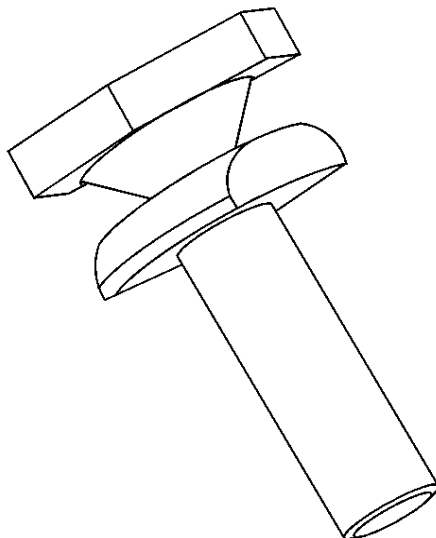

Notice

Use the correct fastener in the correct location. Replacement fasteners must be the correct part

number for that application. Fasteners requiring replacement or fasteners requiring the use of thread locking compound or sealant are identified in the service procedure. Do not use paints, lubricants, or corrosion inhibitors on fasteners or fastener joint surfaces unless specified. These coatings affect fastener torque and joint clamping force and may damage the fastener. Use the correct tightening sequence and specifications when installing fasteners in order to avoid damage to parts and systems.

11. Hand tighten the new "break-away head" fuel sender attaching bolts until finger tight.

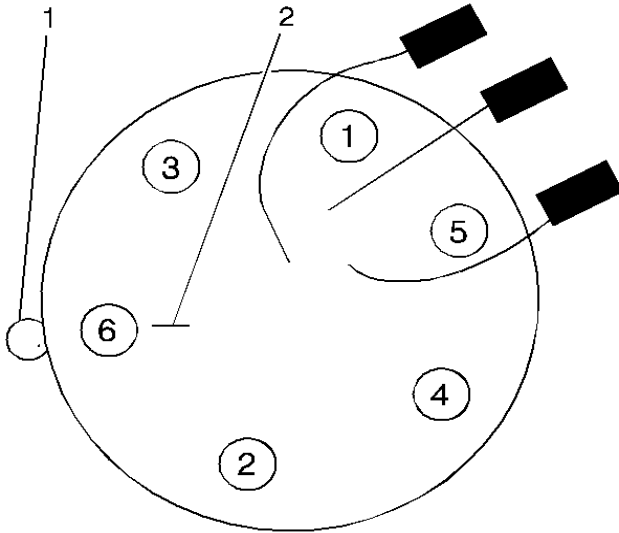

Important

The upper hex head portion of the fuel sender attaching bolts is designed to shear off of the lower section of the bolt when the proper torque is reached. Do not tighten the bolts after the bolt heads have sheared off. A torque wrench or other special tool(s) are not required. Do not use thread locking or other types of sealers or lubricants when installing these bolts and gasket.

12. Tighten the new "break-away head" fuel sender assembly attaching bolts in sequence until the upper hex head portion of the bolts shear off of the lower section.

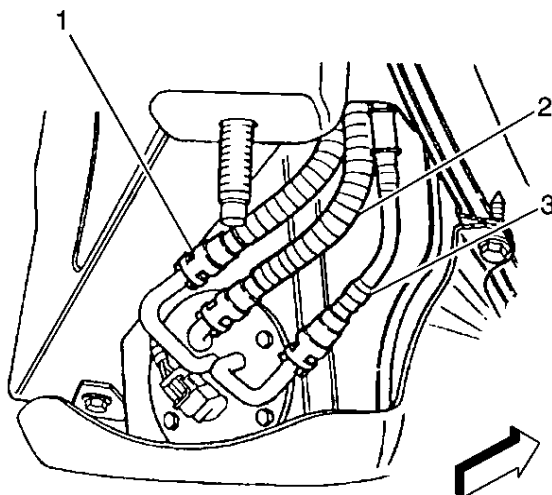



13. Connect the fuel sender fuel feed pipe (1) (jet pump to left tank), the fuel return rear pipe (2), and the fuel feed rear pipe (3). Refer to [Quick Connect Fitting\(s\) Service \(Metal Collar\)](#) or [Quick Connect Fitting\(s\) Service \(Plastic Collar\)](#).
14. Connect the fuel sender electrical connector.

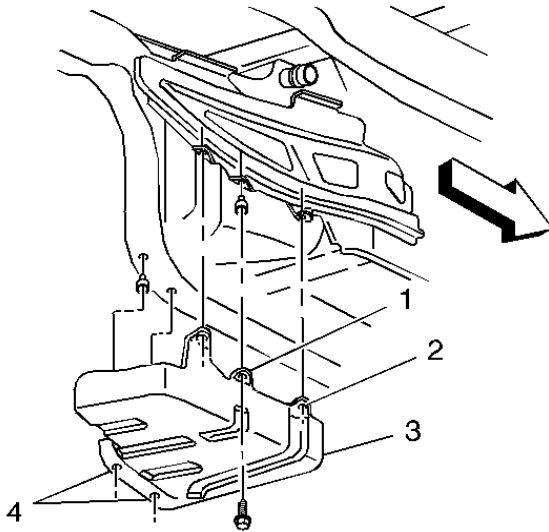

15. Install the fuel tank strap (3).
16. Install the fuel tank strap bolts (1, 2, 4). **Tighten**
 - a. Tighten bolt (2) to 25 N·m (18 lb ft).
 - b. Tighten bolt (1) to 25 N·m (18 lb ft).
 - c. Tighten the remaining bolts (4) to 25 N·m (18 lb ft).

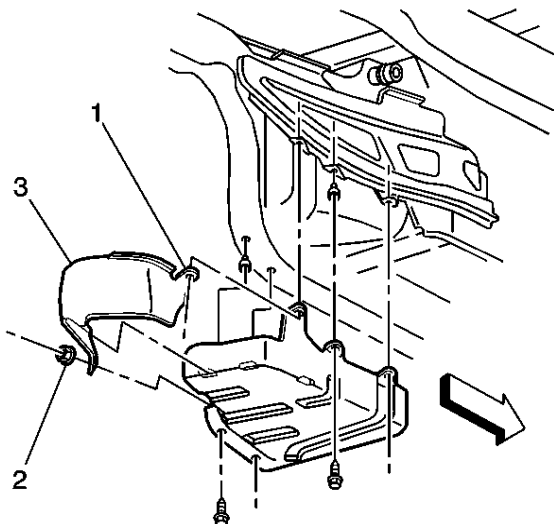

17. Install the fuel tank shield (3).
18. Install the fuel tank shield mount bolt (1).
19. Install the fuel tank shield mount nut (2). **Tighten**
 - o Tighten the fuel tank shield mount bolt to 25 N·m (18 lb ft).

- Tighten the fuel tank shield mount nut to 25 N·m (18 lb ft).
20. Install the rear wheel and tire assembly. Refer to [Tire and Wheel Removal and Installation](#) in Tires and Wheels.
 21. Lower the vehicle.
 22. Refill the fuel system.
 23. Install the fuel filler cap.
 24. Connect the negative battery cable.
 25. Inspect for leaks.
 - A. Turn the ignition switch ON for 2 seconds.
 - B. Turn the ignition switch OFF for 10 seconds.
 - C. Turn the ignition switch ON.
 - D. Check for fuel leaks.
 26. Program the transmitters. Refer to [Transmitter Programming/Synchronization](#) in Keyless Entry.
 27. Perform the idle learn procedure. Refer to *PCM Idle Learn Procedure* .
-

[<- Back](#)[Forward ->](#)

Document ID# 307783
1999 Chevrolet/Geo Corvette

[Print](#)