

&lt;- Back

Forward -&gt;

Document ID# 773313  
2002 Chevrolet Corvette

Print

# Instrument Panel, Gages, and Console Connector End Views

Table 1: [Instrument Panel Cluster \(IPC\)](#)

Table 2: [Engine Oil Temperature \(EOT\) Sensor](#)

Table 3: [Fuel Level Sensor-Right](#)

Table 4: [Engine Oil Level Switch](#)

Table 5: [Engine Oil Pressure \(EOP\) Sensor](#)

## Instrument Panel Cluster (IPC)

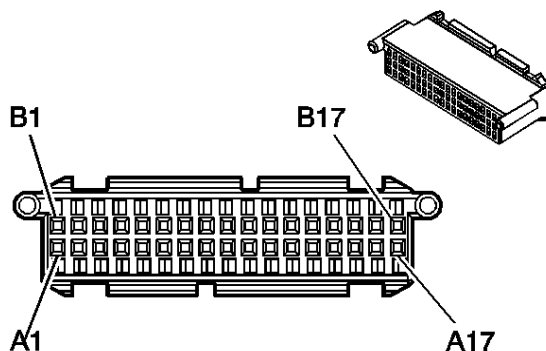

Connector Part Information		<ul style="list-style-type: none"> <li>• 12065803</li> <li>• 34-Way F Micro-Pack 100 Series (BLK)</li> </ul>	
Pin	Wire Color	Circuit No.	Function
A1	--	--	Not Used
A2	LT GRN	11	Headlamp High Beam Supply Voltage
A3	WHT	103	Headlamp Switch Headlamps On Signal
A4	BLK/WHT	99	Windshield Washer Fluid Level Signal
A5	--	--	Not Used
A6	TAN/WHT	33	Brake Warning Indicator Control
A7	DK GRN/WHT	817	VSS Signal
A8	BLK	150	Ground
A9	--	--	Not Used
A10	DK GRN/WHT	357	Oil Temperature Sensor Signal
A11	GRY	1036	IPC Class 2 Serial Data

A12	--	--	Not Used
A13	PNK	139	Ignition 1 Voltage
A14	ORN	1640	Battery Positive Voltage
A15	LT BLU	14	Turn Signal Lamp Feed-LF
A16	DK BLU	15	Turn Signal Lamp Feed-RF
A17	WHT	121	Engine Speed Signal
B1	--	--	Not Used
B2	BLK/WHT	238	Driver Seat Belt Switch Signal
B3	--	--	Not Used
B4	PPL	333	Brake Warning Indicator Supply Voltage [1]
B5	WHT	717	Illuminated Display Signal
B6	GRY/BLK	1458	Instrument Panel Lamp Supply Voltage - 4
B7	--	--	Not Used
B8	BLK	470	Low Reference
B9-B10	--	--	Not Used
B11	WHT	375	Skip Shift Indicator Control
B12	--	--	Not Used
B13	BLK/WHT	851	Ground
B14	--	--	Not Used
B15	BLK	150	Ground
B16	BRN/WHT	419	MIL Control
B17	BRN	9	Park Lamp Supply Voltage

### Engine Oil Temperature (EOT) Sensor

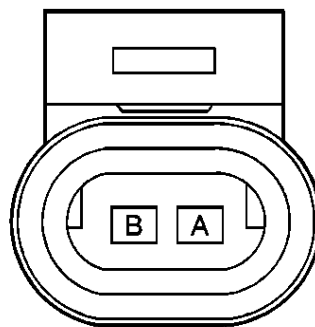

#### Connector Part Information

- 12162192
- 2-Way F Metri-Pack 150.2 Series (BLK)

Pin	Wire Color	Circuit No.	Function
A	BLK	470	Low Reference

B	DK GRN/WHT	357	Oil Temperature Sensor Signal
---	------------	-----	-------------------------------

**Fuel Level Sensor-Right**

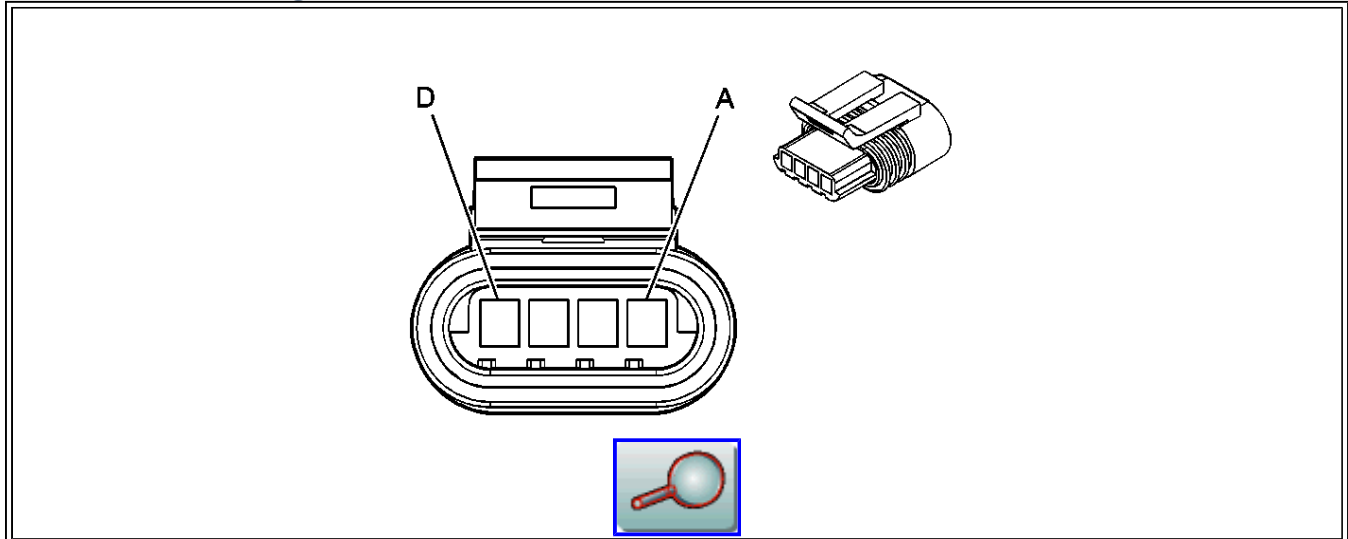

<b>Connector Part Information</b>		<ul style="list-style-type: none"> <li>• 12162187</li> <li>• 4-Way F Metri-Pack 150.2 Series (BLK)</li> </ul>	
Pin	Wire Color	Circuit No.	Function
A	--	--	Not Used
B	GRY	720	Sensor Return
C	LT BLU	1937	Right Fuel Level Sensor - Signal
D	BLK	150	Ground

**Engine Oil Level Switch**

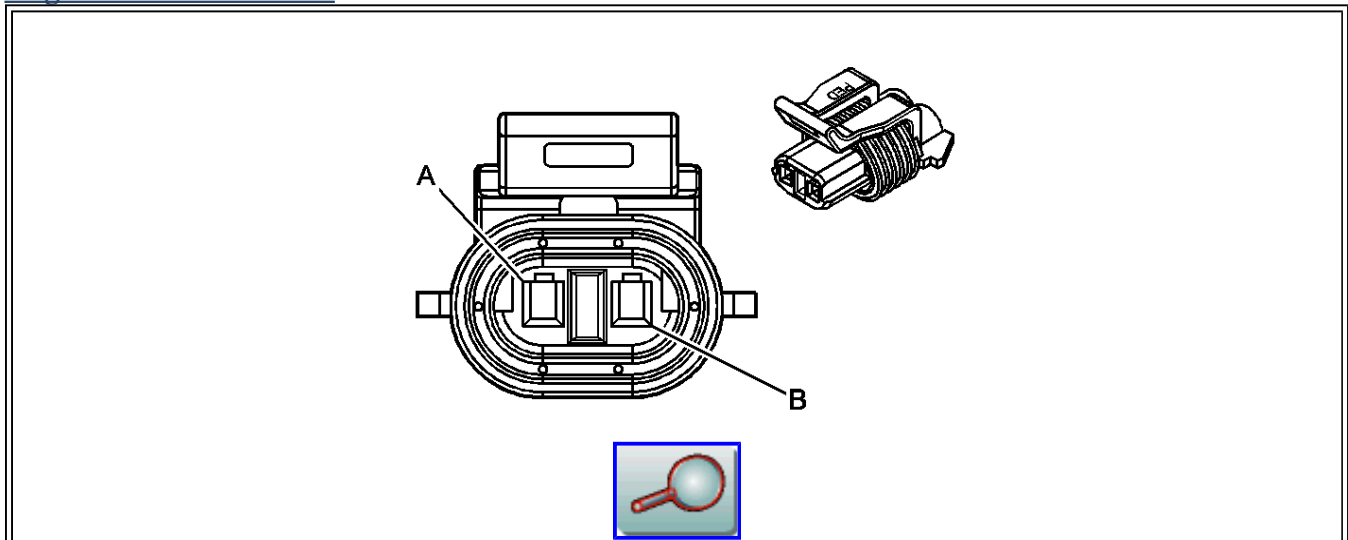

<b>Connector Part Information</b>		<ul style="list-style-type: none"> <li>• 12052635</li> <li>• 2-Way F Metri-Pack 150 Series (BLK)</li> </ul>	
Pin	Wire Color	Circuit No.	Function
A	BRN	1174	Engine Oil Level Sensor - Signal
B	BLK	150	Ground

**Engine Oil Pressure (EOP) Sensor**

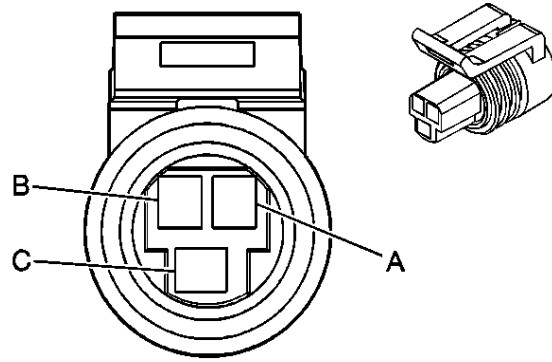

<b>Connector Part Information</b>		<ul style="list-style-type: none"> <li>• 12065286</li> <li>• 3-Way F Metri-Pack 150 Series (BLK)</li> </ul>	
Pin	Wire Color	Circuit No.	Function
A	BLK	452	Engine Oil Pressure (EOP) Sensor - Return
B	GRY	596	5.0V Reference
C	TAN/WHT	331	Engine Oil Pressure (EOP) Sensor - Signal

<- Back

Forward ->

**Document ID# 773313**  
**2002 Chevrolet Corvette**

Print