

# C6-A6 Paddle Swap

**Purpose: To make the right paddle up-shift when pulled and the left paddle down-shift when pulled.**

This modification was originally posted to the Corvette Forum on 11-24-2006, 06:11 PM --

<http://forums.corvetteforum.com/c6-corvette-general-discussion/1555475-reprogram-paddle-shift.html> -- Post #22

I have cleaned up the instructions to simplify them based on others who have also made this mod. At the time, I believe I was the first to attempt to change the way the paddles worked and because of that I tried things that weren't really necessary to accomplish this relatively easy task.

Also, others have chosen to purchase a new right-side paddle that does the same thing. I went with free as it was all that was available at the time.

Here's the story --

I wanted to be able to pull up on the right paddle to up-shift as long as I have owned my 2006 C6 while being able to downshift by pulling up on the left paddle. I had guessed that it would just be a matter of switching some wires and that turned out to be true. After a year of ownership a wiring diagram was posted to the Corvette Forum and the solution seemed near. I set out to see how to swap the wires.

Below the right paddle is shown in red and the wire colors marked on the schematic.

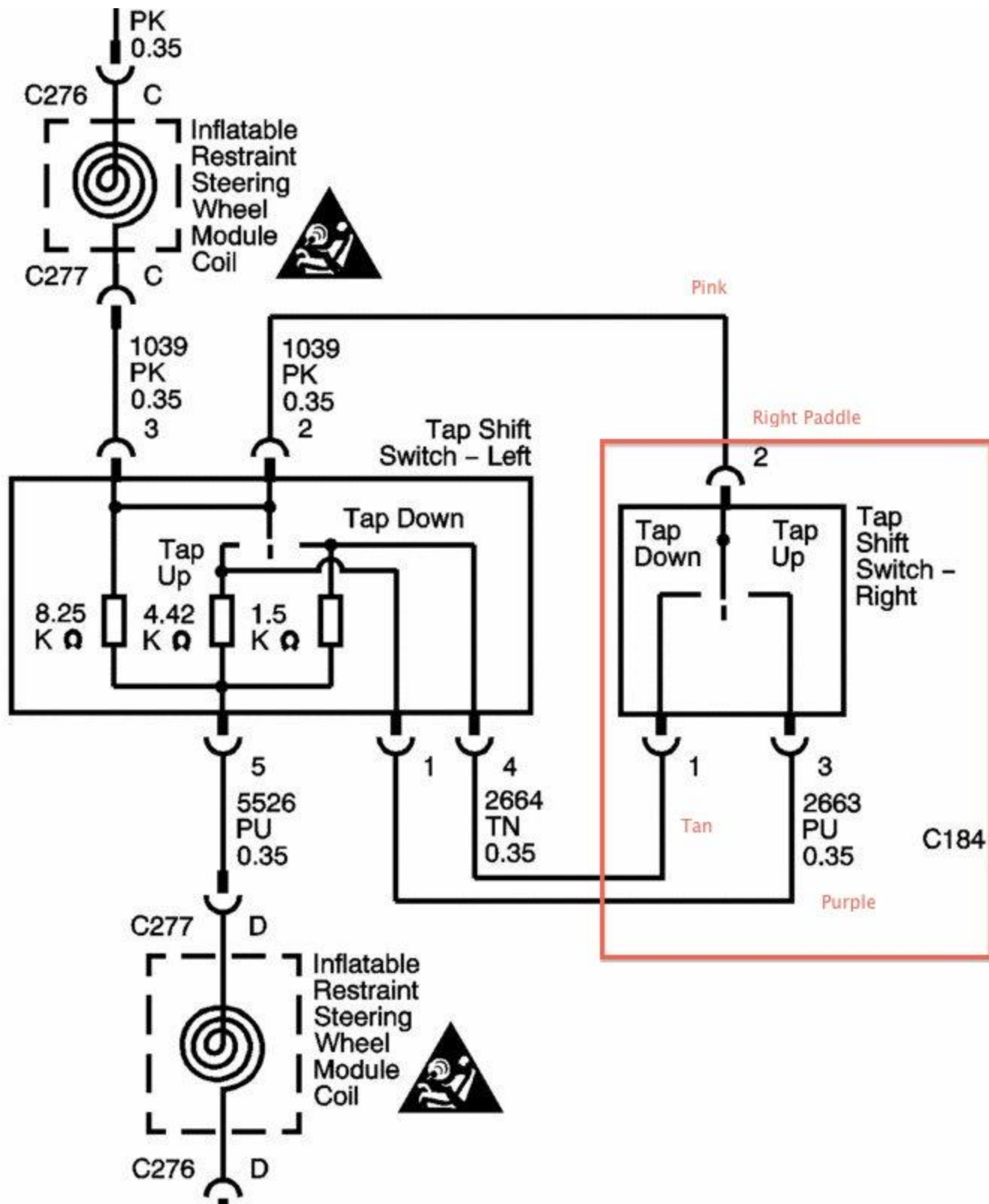

First thing, for your own safety disable the airbag in the steering

wheel. I disconnected the ground wire. It is next to the fuse box in the engine bay and takes a deep-well 13mm socket. Wait at least 10 minutes before working with the airbag.



Next step is to remove the airbag in the center of the wheel. There are two access holes -- one on each lower side of the wheel.



You need to insert a blunt object to press on a spring-wire holding a tapered retaining pin on each side. I used a small punch. A large wire or small screwdriver will also work.



Here you see the spring-wire that locks the airbag in place (notice the center hole.)

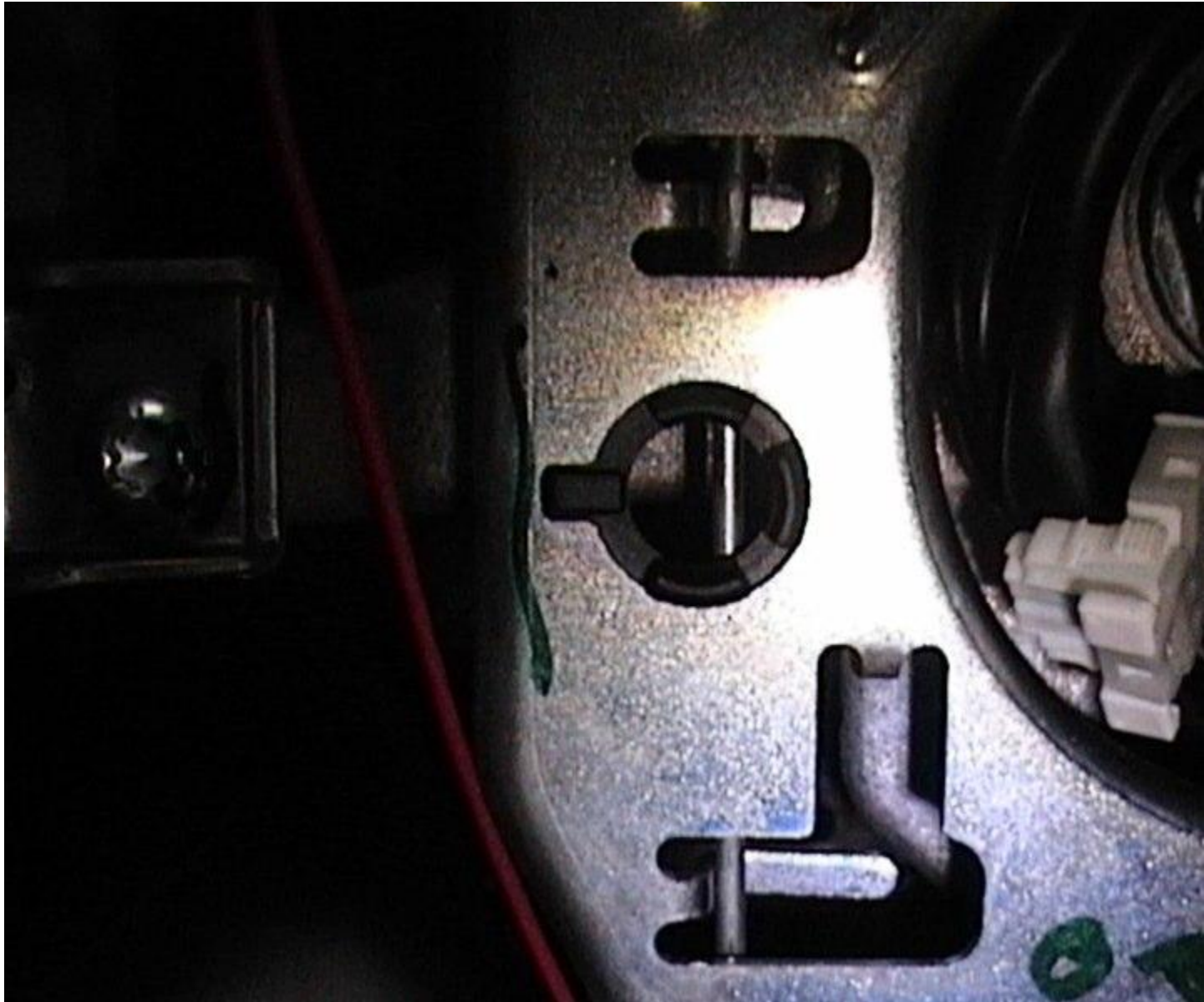

The next photo below shows the spring-wire pushed back that allows the airbag to pull out. You can see the punch inserted.

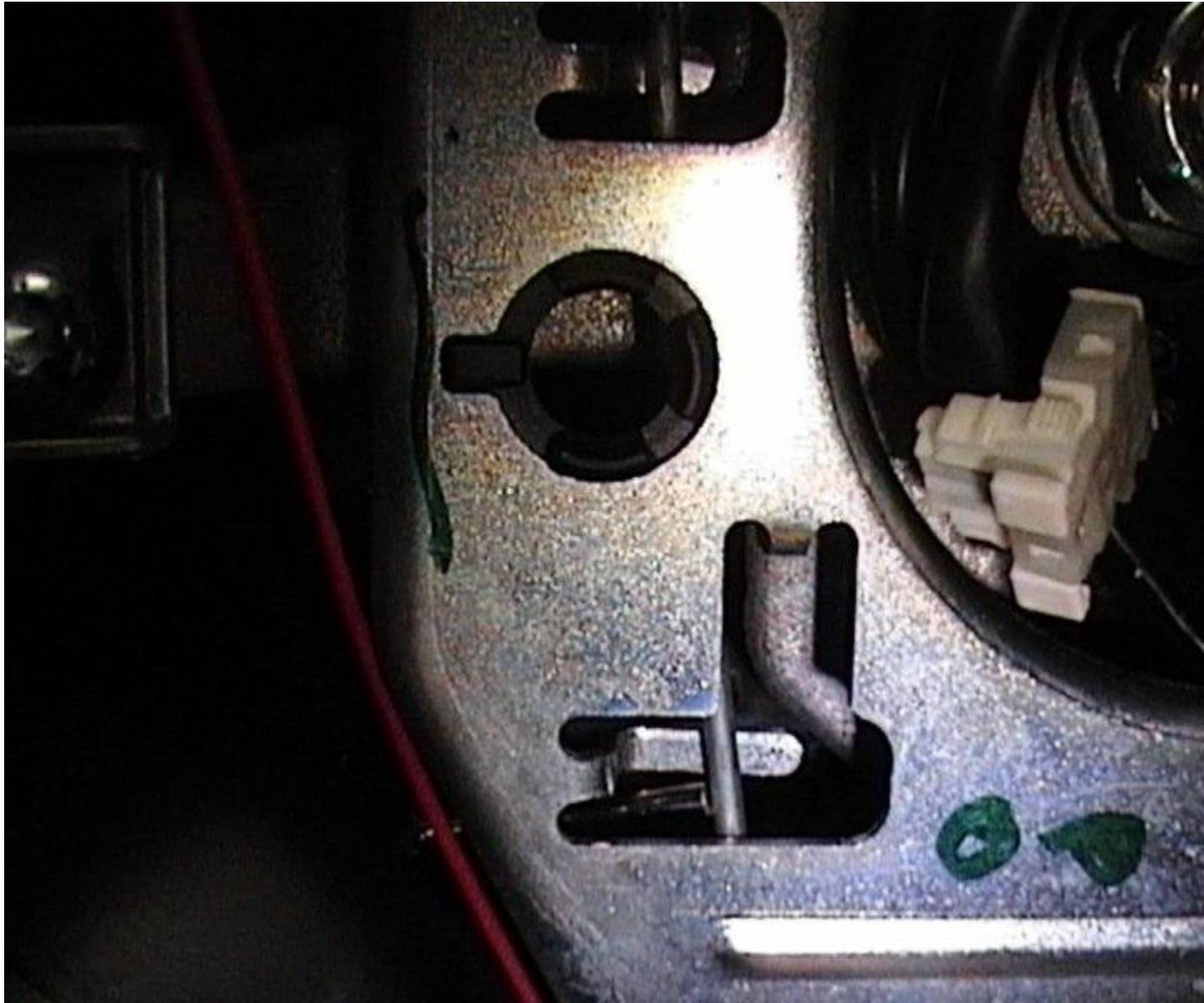

Pull the airbag toward you as you press the spring-wire and it will release as shown below.





You'll then be able to see the right paddle and its connector. To remove the paddle -- as it may be necessary to unplug the connector -- unscrew the two #20 Torx, unplug the connector and remove.



Here's the paddle removed and the brown plug removed (that contains the wires you need to swap.)





Here's the brown plug that is removed to work on.



I then opened up the connector by sliding the white retaining clip out by pressing in on the sides. Here's a close up showing the wires (brown/tan, pink, purple.)

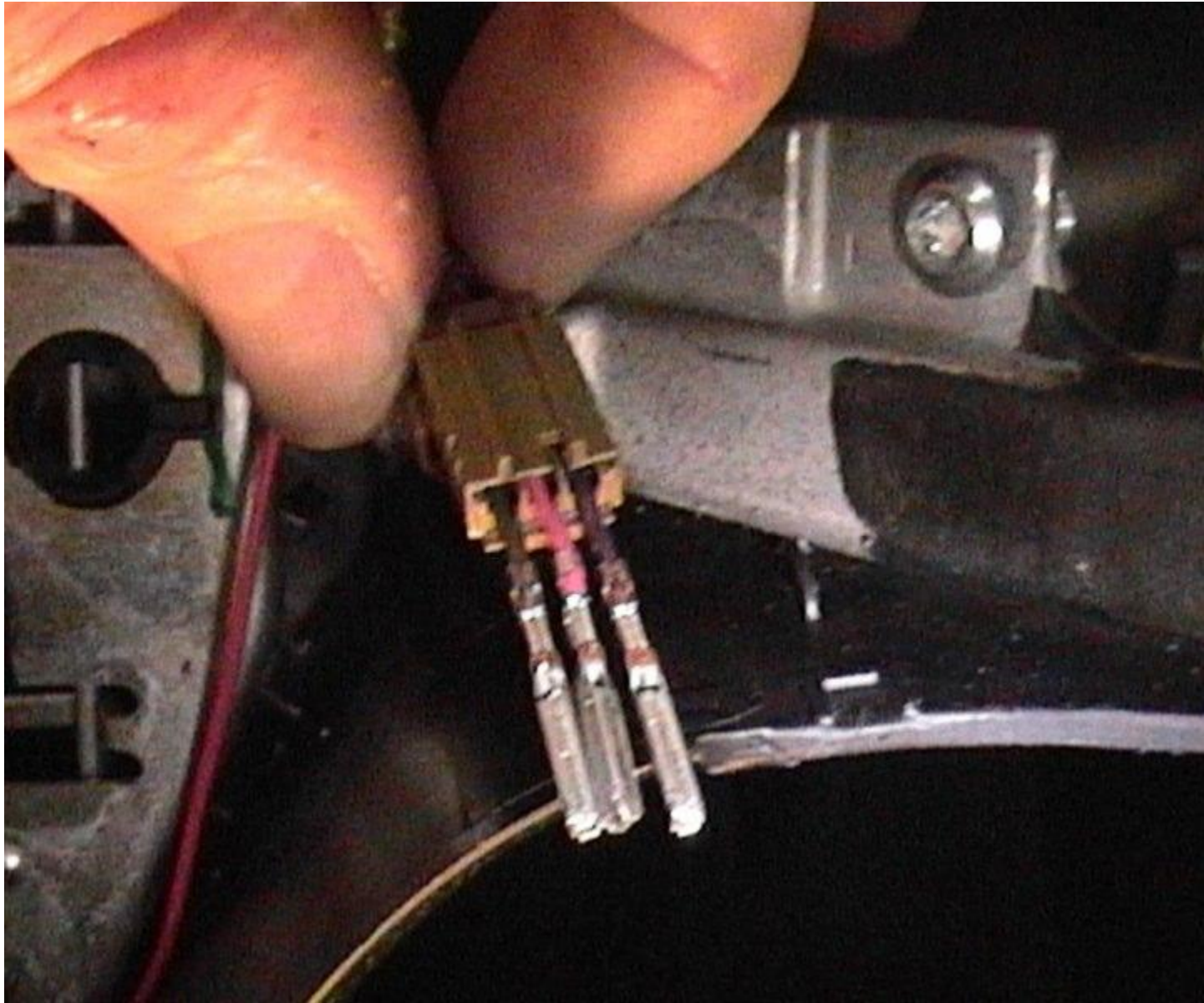

I was then able to push in a small punch enough to release whatever clip is holding the wires in and slide them out the back. When I inserted the punch (a wire would also work) into the connector to release the wires it flattened whatever was stopping the wires from pulling out. I was able to remove the tan and purple wires, switch their location, and push them back into the connector. They are now able to slide out but holding them in place when you reconnect the paddle will provide a secure connection. You can also re-bend the locking tap to secure them.



To reassemble -- reverse your steps. Connect the right paddle to its wire connector and mount it with the two #20 Torx (if removed.) Replace the cover with one #20 Torx.

Reinstall the airbag connectors (if removed) and push in the yellow retaining clips to lock them in place. Check that your wires aren't crimped and place the tapered pins into the holes on the horn ring. Push in on the airbag to lock into the retaining spring-wire.

Reconnect the battery ground wire and you're done. You'll need to re-index your windows by holding the up switch for 5 seconds.

I tried it out before getting everything back together. Pulling up on the left downshifted and pulling up on the right up-shifted. Pressing down on the thumb buttons on the top still work as opposites on each side. This comes in handy if you are driving along with only one hand on the wheel and need to change gears.

I've used this mod now for close to six years with no problem. I use the paddles most of the time I drive and run with them in autox and HPDE events. In all cases, I find it much more intuitive to use them in this manner rather than as supplied. As with any change, you'll

need to keep using the paddles to become comfortable with this change.