

## Side Door Opening Frame Replacement

### Tools Required

[J 42058](#) Frame Adapter Clamp

### Removal Procedure

**Caution:** Refer to [Approved Equipment for Collision Repair Caution](#) in the Preface section.

The side door opening frame is made of sheet molded compound (SMC), and is bonded to the side structure and frame rail with structural adhesive.

1. Disable the SIR system. Refer to [SIR Disabling and Enabling](#).
2. Disconnect the negative battery cable. Refer to [Battery Negative Cable Disconnection and Connection](#).

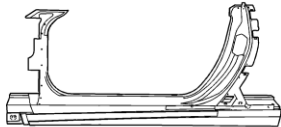

3. Remove all related panels and components.

**Caution:** Refer to [Actions to Take When Working with Fuel Caution](#) in the Preface section.

4. Verify that the fuel inlet is sealed before proceeding with repair procedure.

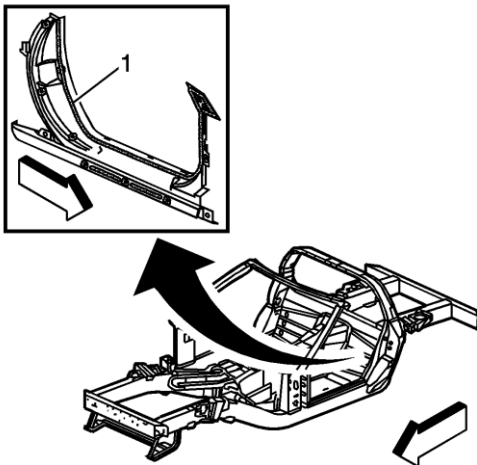

5. Remove the door frame by applying heat and pry to detach the adhesive (1) along the bonding surface.

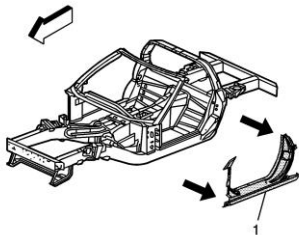

Remove the door frame (1) from the vehicle.

6. Note the location of the adhesive and remove all remaining loose adhesive.
7. Inspect the side structure and frame rails for damage.
8. Repair as much of the damage as possible to the factory specifications.
9. Use [J 42058](#) to secure the vehicle if pulling and straightening is required.

## Installation Procedure

1. Before applying adhesive dry fit the door frame for proper fit and alignment.  
**Important:** DO NOT top coat any bonding surface. Use primer only on bonding surfaces. Refer to adhesive manufacturer's recommendations.
2. Clean and prepare all bonding mating surfaces according to adhesive manufacturer's recommendations.

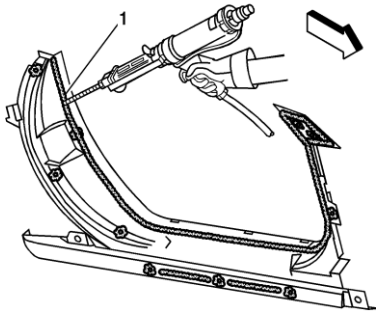

3. Apply a consistent bead of structural adhesive 10 mm (3/8 in) in diameter to the inner surface of the door frame to mate with the side structure and frame rail and to all areas originally bonded. Refer to [Sheet Molded Compound \(SMC\) Panel Bonding](#).

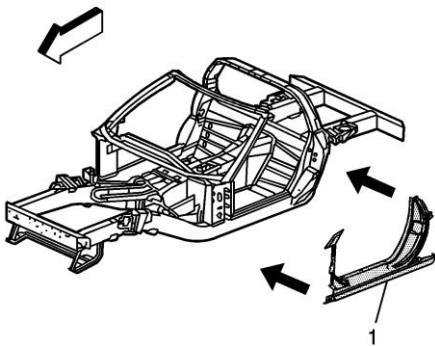

4. Position the door frame (1) to the vehicle.
5. Apply pressure to the door frame to set the adhesive.
6. Clamp or tape the door frame in place as necessary.
7. Remove any excess adhesive.
8. Install all related panels and components.
9. Connect the negative battery cable. Refer to [Battery Negative Cable Disconnection and Connection](#).
10. Enable the SIR system. Refer to [SIR Disabling and Enabling](#).

---

### Sheet Molded Compound (SMC) Panel Bonding

This is intended to provide general guidelines for sheet molded compound (SMC) and carbon fiber adhesive bonding of full panel replacement in regards to collision repair procedures.

Sectioning, partial panel of full panels, is not supported by General Motors unless specifically documented in a Service Bulletin or Manual.

#### **Important:**

- Prepare the surfaces to be bonded according to adhesive manufacturer's recommendations. Many adhesive manufacturers have different preparation methods. Do not intermix adhesive

manufacturers systems. Mixing materials from different manufacturers can produce unsatisfactory results.

- DO NOT top coat any adhesive bonding mating surface. Use primer only on bonding surfaces. Refer to adhesive manufacturer's recommendations for priming applications.

Adhesives currently meeting the performance requirements include General Motors materials and products manufactured by Ashland and Lord Fusor. At this time, ONLY the adhesive products listed below meet this guideline:

<b>GM Goodwrench®</b>	<b>GMSPO of Canada</b>	<b>Ashland Pliogrip Structural Adhesives Crest Industries, Inc 1-800-822-4100</b>	<b>Lord Fusor Structural Adhesive</b>	<b>Product Type</b>
89020330	8902332	7770B	127 EZ	Medium Set
N/A	N/A	7779B	N/A	Fast Set

Canadian applications may use U.S. part numbers. Refer to your GM Dealer Parts Department for the correct part number applications.