

Engine Control Module (ECM) X2 (LS9)

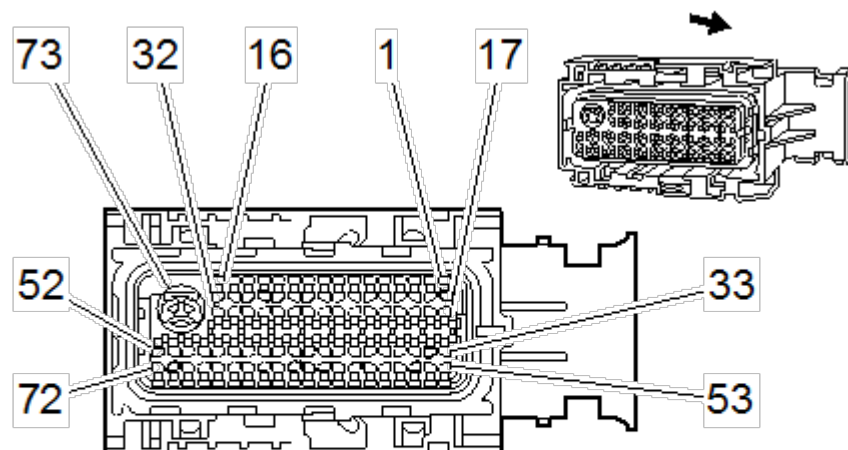

Connector Part Information

- Harness Type: Engine
- OEM Connector: 34566-1673
- Service Connector: 88988931
- Description: 73-Way F 0.64/2.8 Series, Sealed (BK with BK Terminal Position Assurance Lock)

Terminal Part Information

- Pins: 1-5, 11-13, 17, 18, 25, 33, 34, 41, 53-55, 68, 69
- Terminated Lead: 13575812
- Release Tool: J-38125-213
- Diagnostic Test Probe: J-35616-64B (L-BU)
- Terminal/Tray: 33467-0005/23
- Core/Insulation Crimp: J/J
- Pins: 6-9, 23, 24, 27, 29, 39, 40, 42-45, 59, 60, 62-67
- Terminated Lead: 13575811
- Release Tool: J-38125-213
- Diagnostic Test Probe: J-35616-64B (L-BU)
- Terminal/Tray: 33467-0003/23
- Core/Insulation Crimp: H/H
- Pins: 16, 19, 32, 35, 48, 49, 52, 70-72
- Terminated Lead: 13575812

© 2017 General Motors. All rights reserved.

- Release Tool: J-38125-213
 - Diagnostic Test Probe: J-35616-64B (L-BU)
 - Terminal/Tray: 33467-0005/23
 - Core/Insulation Crimp: K/K
-
- Pin: 73
 - Terminated Lead: Service by Terminal – 7116-4152-02
 - Release Tool: J-38125-11A
 - Diagnostic Test Probe: J-35616-35 (VT)
 - Terminal/Tray: 7116-4152-02/9
 - Core/Insulation Crimp: A/5

Engine Control Module (ECM) X2 (LS9)

Pin	Wire	Circuit	Function
1	0.5 PU	2121	IC1 Control
2	0.5 TN	1664	HO2S Low Signal – Bank 1 Sensor 1
3	0.5 PU/WH	1665	HO2S High Signal – Bank 1 Sensor 1
4	0.5 PU/WH	1668	HO2S High Signal Bank 1 Sensor 2
5	0.5 TN/WH	1669	HO2S Low Signal Bank 1 Sensor 2
6	0.35 L-BU	1876	Knock Sensor 2 Signal
7	0.35 GY	2303	Knock Sensor 2 Signal
8	0.35 D-BU	496	Knock Sensor 1 Signal
9	0.35 GY	1716	Knock Sensor 1 Signal
10	—	—	Not Used
11	0.5 YE	581	Throttle Actuator Control (TAC) Motor Control – 1
12	0.5 BN	582	Throttle Actuator Control (TAC) Motor Control – 2
13	0.5 PK	439	Ignition Voltage
14–15	—	—	Not Used
16	0.8 PK/BK	1746	Fuel Injector 3 Control

Pin	Wire	Circuit	Function
17	0.5 PK/WH	2128	IC 8 Control
18	0.5 D-GN/WH	2124	IC 4 Control
19	0.8 BN/WH	2130	Low Reference
20-22	—	—	Not Used
23	0.35 BN	6266	Low Reference
24	0.35 BK	2755	Low Reference
25	0.5 D-GN	7125	Super Charger Inlet Air Pressure Sensor Return
26	—	—	Not Used
27	0.35 GY/BK	6272	Low Reference
28	—	—	Not Used
29	0.35 TN/WH	1704	Low Reference
30-31	—	—	Not Used
32	0.8 L-GN/BK	1745	Fuel Injector 2 Control
33	0.5 OG	2127	IC 7 Control
34	0.5 D-GN	2125	IC 5 Control
35	0.8 BN	2129	Low Reference
36-38	—	—	Not Used
39	0.35 D-BU	6259	5-Volt Reference
40	0.35 GY	2705	5-Volt Reference
41	0.5 YE/BK	7124	5-Volt Reference
42	0.35 TN	2760	Low Reference
43	0.35 PU/WH	6270	5-Volt Reference
44	0.35 L-BU/BK	1688	5-Volt Reference

Pin	Wire	Circuit	Function
45	0.35 OG/BK	586	Low Reference
46-47	—	—	Not Used
48	0.8 D-BU/WH	878	Fuel Injector 8 Control
49	0.8 TN/WH	845	Fuel Injector 5 Control
50-51	—	—	Not Used
52	0.8 YE/BK	846	Fuel Injector 6 Control
53	0.5 OG/WH	2122	IC 2 Control
54	0.5 L-BU/WH	2126	IC 6 Control
55	0.5 L-BU	2123	IC 3 Control
56-58	—	—	Not Used
59	0.35 D-BU/WH	6265	Camshaft Position Sensor Signal
60	0.35 TN/WH	331	Oil Pressure Sensor Signal
61	—	—	Not Used
62	0.35 TN	472	Intake Air Temperature Sensor Signal
63	0.35 WH/BK	6271	Crankshaft Position Sensor Signal
64	0.35 D-GN	485	Throttle Position Sensor 1 Signal
65	0.35 TN/WH	585	Transmission Fluid Temperature (TFT) Sensor Signal
66	0.35 PU	486	Throttle Position Signal 2
67	0.35 YE	492	Mass Air Flow (MAF) Sensor Signal
68	0.5 GY/WH	3113	H02S Heater Low Control Bank 1 Sensor 1
69	0.5 GY/WH	3122	H02S Heater Low Control – Bank 1 Sensor 2

Pin	Wire	Circuit	Function
70	0.8 L-BU/BK	844	Fuel Injector 4 Control
71	0.8 OG/BK	877	Fuel Injector 7 Control
72	0.8 TN	1744	Fuel Injector 1 Control
73	3.0 BK/WH	451	Ground