

## #05-03-08-002E: Information on Diagnosis and Replacement of Shock Absorber and Strut Due to Fluid Leak - (May 31, 2012)

**Subject: Information on Diagnosis and Replacement of Shock Absorber and Strut Due to Fluid Leak**



**Models: 2013 and Prior GM Passenger Cars and Trucks**

**This bulletin is being revised to add the 2013 model year. Please discard Corporate Bulletin Number 05-03-08-002D (Section 03 – Suspension).**

This bulletin is intended to help identify the severity of shock absorber and strut fluid seepage. Improper diagnosis may lead to components being replaced that are within the manufacturer's specification. Shock absorbers and strut assemblies are fluid-filled components and will normally exhibit some seepage. Seepage is defined as oil film or dust accumulation on the exterior of the shock housing. Shock absorbers and struts are not to be replaced under warranty for seepage. Use the following information to determine if the condition is normal acceptable seepage or a defective component.

**Important:** Electronically controlled shock absorbers (MR) may have a tendency to attract dust to this oil film. Often this film and dust can be wiped off and will not return until similar mileage is accumulated again.

### Inspection Procedure

**Note:** The shock absorber or strut assembly DOES NOT have to be removed from the vehicle to perform the following inspection procedure.

Use the following descriptions and graphics to determine the serviceability of the component.

## Shock Absorbers

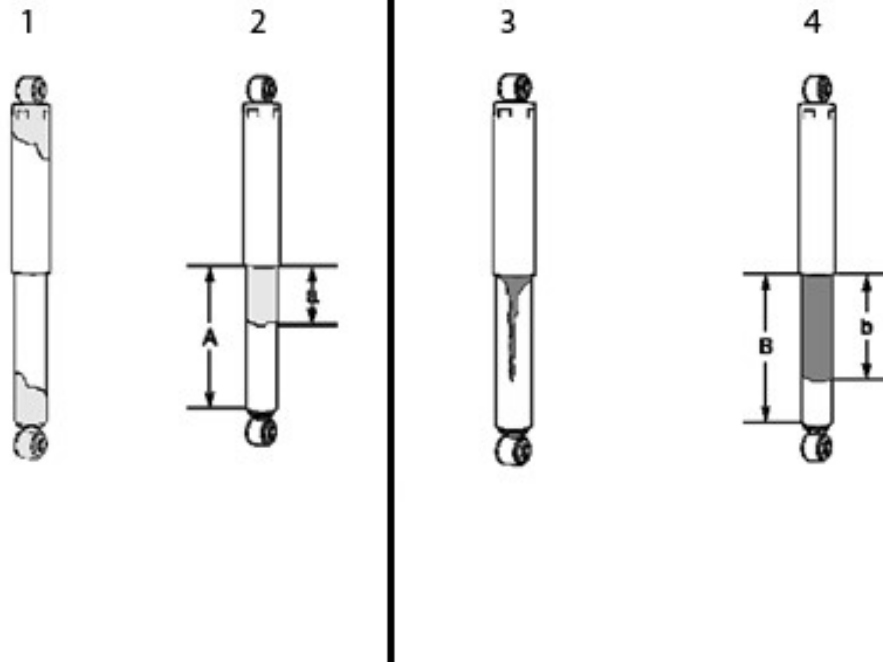

**Do Not Replace shock absorbers** displaying condition 1 or 2 levels of seepage.

1. Oil or fluid residue only on the bottom or top of the shock absorber and not originating from the shaft seal (the upper part of the lower shock tube).
2. Light film/residue on approximately 1/3 (a) or less of the lower shock tube (A) and originating from the shaft seal.

**Replace shock absorbers** displaying conditions 3 and 4 levels of leaks.

3. Oil drip or trail down the lower shock tube and originating from the shaft seal.
4. An extreme wet film of oil covering more than 1/3 (b) of the lower shock tube and originating from the shaft seal.

## Coil-over Shock Absorber

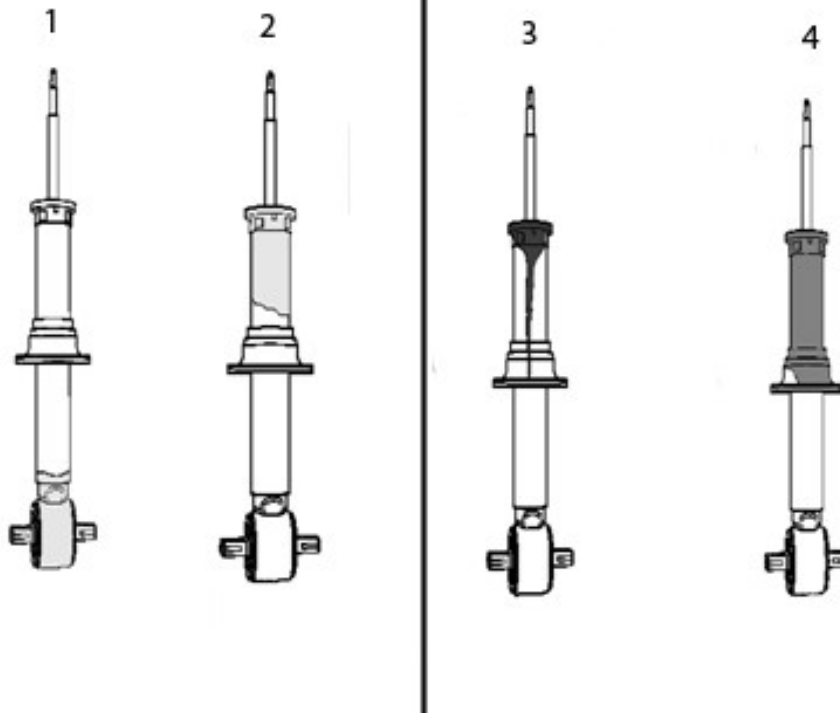

**Do Not Replace coil-over shock absorbers** displaying condition 1 or 2 levels of seepage.

1. Oil or fluid residue only on the bottom of the lower shock absorber tube or the coil-over shock absorber components and not originating from the shaft seal (located at the top of the coil-over shock tube).
2. Light film/residue on the shock absorber tube, but not on the spring seat and originating from the shaft seal.

**Replace coil-over shock absorbers** displaying conditions 3 and 4 levels of leaks.

3. Oil drip or trail down the lower shock tube and originating from the shaft seal.
4. An extreme, wet film of oil covering the shock absorber tube and pooling in the spring seat and originating from the shaft seal.

## Struts

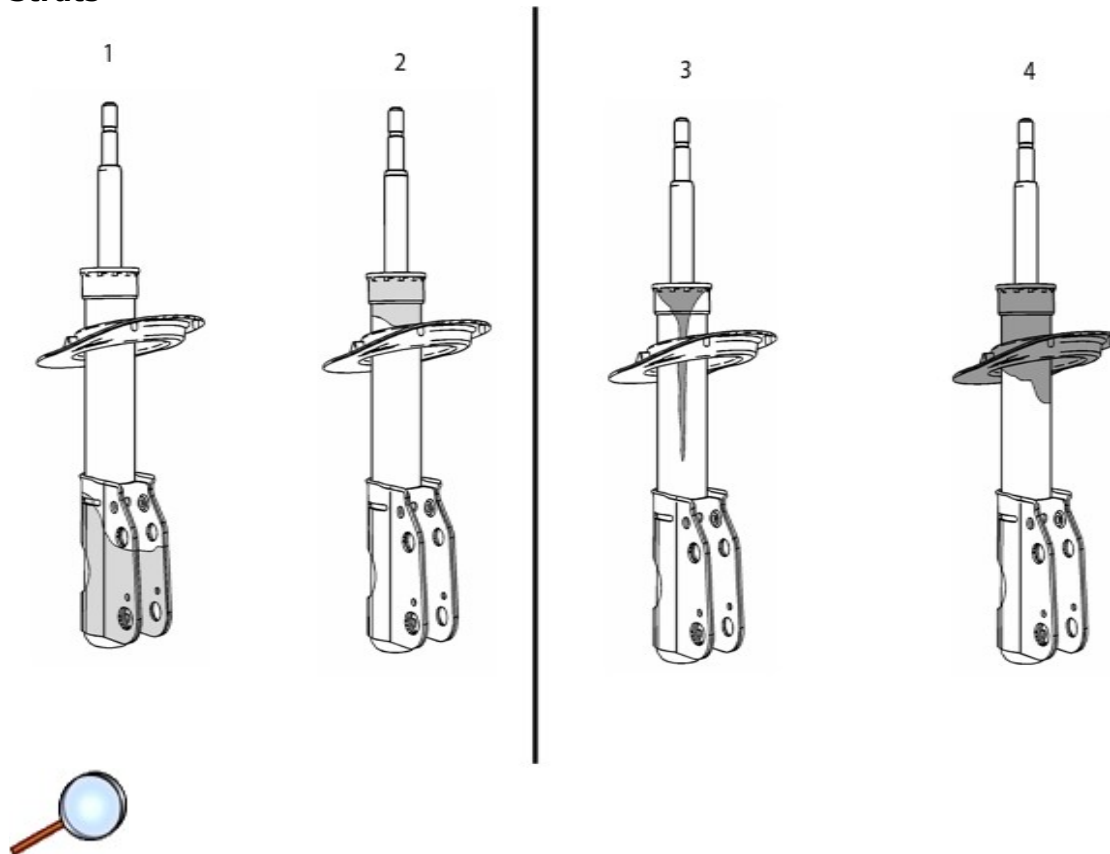

**Do Not Replace Struts** displaying condition 1 or 2 levels of seepage.

1. Oil or fluid residue only on the bottom of the strut tube or on other strut components and not originating from the shaft seal.
2. Light film/residue on the strut tube, but not on the spring seat and originating from the shaft seal.

**Replace Struts** displaying conditions 3 and 4 levels of leaks.

3. Oil drip or trail down the strut tube and originating from the shaft seal (located at the top of the strut tube).
4. Extreme wet film of oil covering the strut tube and pooling in the spring seat and originating from the shaft seal.

### Correction

Use the information published in SI for diagnosis and repair.

Use the applicable published labor operation.

GM bulletins are intended for use by professional technicians, NOT a "do-it-yourselfer". They are written to inform these technicians of conditions that may occur on some vehicles, or to provide information that could assist in the proper service of a vehicle. Properly trained technicians have the equipment, tools, safety instructions, and know-how to do a job properly and safely. If a condition is described, DO NOT assume that the bulletin applies to your vehicle, or that your vehicle will have that condition. See your GM dealer for information on whether your vehicle may benefit from the information.



WE SUPPORT  
VOLUNTARY  
TECHNICIAN  
CERTIFICATION