

## #PI1276A: Difficult to Shift into Gear, Intermittent Gear Pop Out and/or Mushy Shifts (No Grind) - (Sep 10, 2014)

**Subject:** Difficult to Shift into Gear, Intermittent Gear Pop Out and/or Mushy Shifts (No Grind)



**Models:** 2014 Chevrolet Corvette

**Equipped with 7 Speed Manual Transmission (RPO MEL or MEP)**

**This PI has been revised to update the Condition/Concern. Please discard PI1276.**

### Condition/Concern

Some customers may comment that the transmission is difficult to shift into gear, intermittent gear pop out occurs, or that the shifter has a mushiness to the shift and lacks crispness in shifts.

### Recommendation/Instructions

The shifter assembly neutral position will need to be re-aligned following the procedure below:

1. Remove the front floor lower console. Refer to Front Floor Lower Console Replacement in SI.

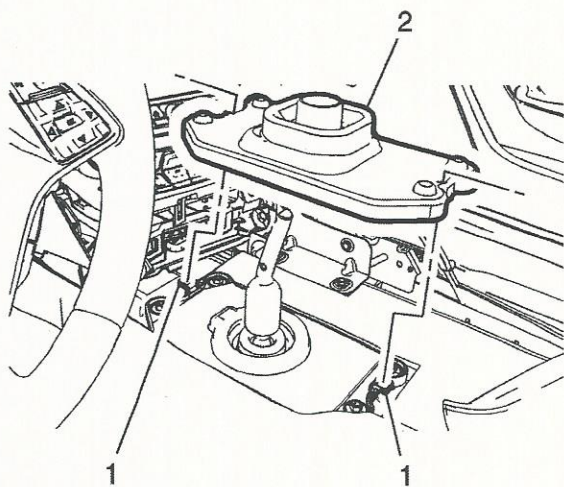

2. Remove the upper closeout boot (2) from the transmission control assembly.

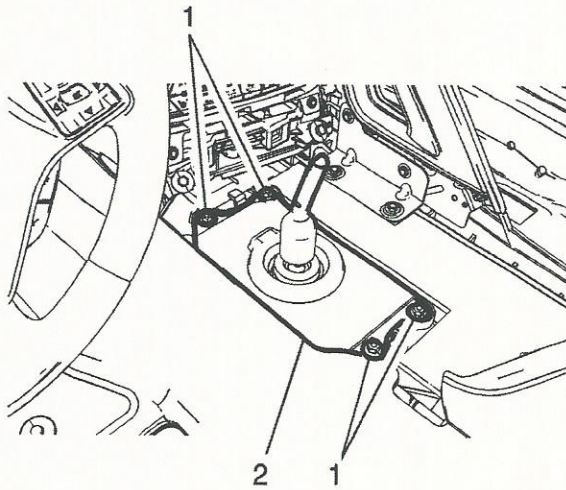

3. Remove the transmission control lower closeout boot retaining nuts (1).
4. Remove the transmission lower closeout boot (2) assembly.

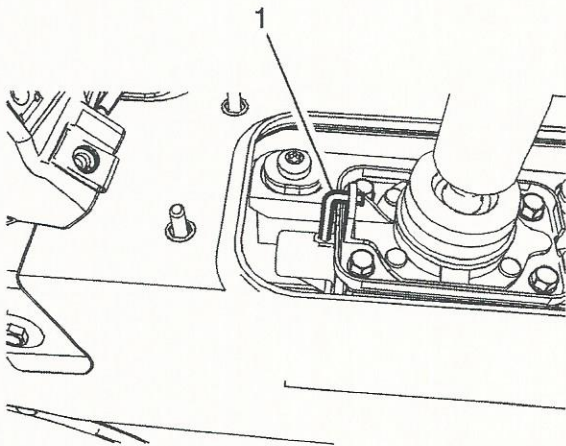

5. Place the shifter into NEUTRAL.
6. Press down to engage the shift control neutral lock pin (1).

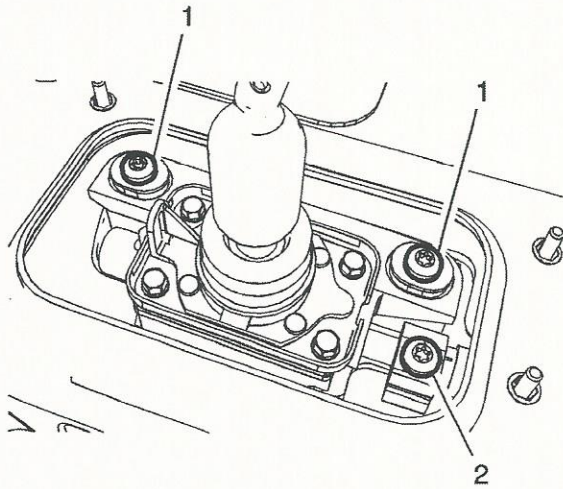

7. Loosen and remove the transmission shift rod clamp bolt (2).
8. Loosen and remove the shift control mounting bolts (1).
9. Re-align the shifter and secure by doing the following:

**Important:** The sequence of steps are critical to shift quality.

- 9.1. Place the bolt in the clamp (2).

**Important:** The bolt must be inserted into the non-threaded hole first, so that it passes freely through to the opposite hole which is threaded.

- 9.2. Thread the bolt (2) by hand 2-3 turns.
- 9.3. Place the bolts in shifter attachment slots (1) and thread 2-3 turns.

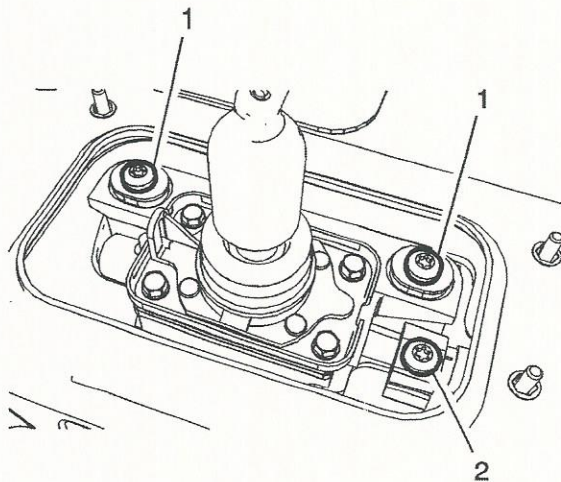

- 9.4. Inspect for proper alignment in the Neutral position.



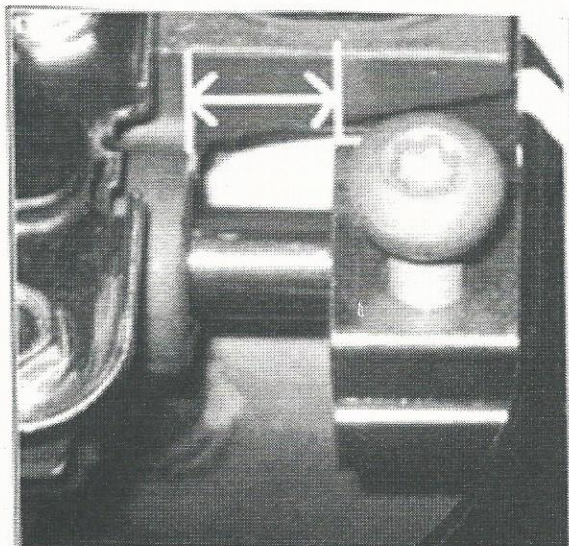

9.5. Fix if incorrectly aligned by grabbing the linkage and push/pull to the proper gate.

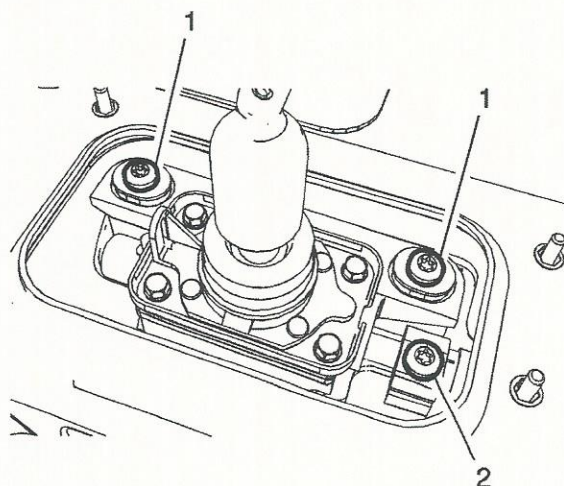

9.6. Tighten the shift control mounting bolts (1) to 30N•m (22 lb ft).

9.7. Tighten the transmission shift rod clamp bolt (2) to 30N•m (22 lb ft).

**Caution:** Refer to fastener cautions in SI.

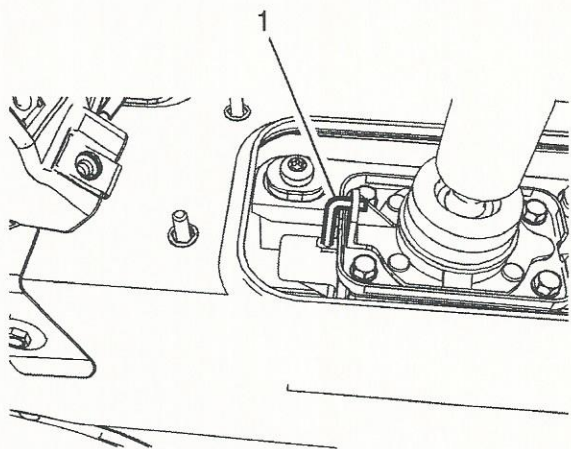

10. Lift to release the shift control neutral lock pin (1).

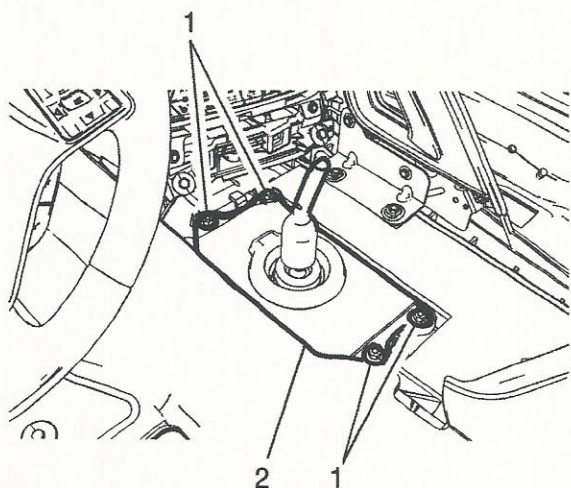

11. Install the lower transmission control closeout boot (2).

**Important:** Check that the closeout boot fully seats to the shift control lever seal and the base of the shift control assembly.

12. Install the shift control closeout boot retaining nuts.

**Tighten**

Tighten the nuts to 6N•m (53 lb in).

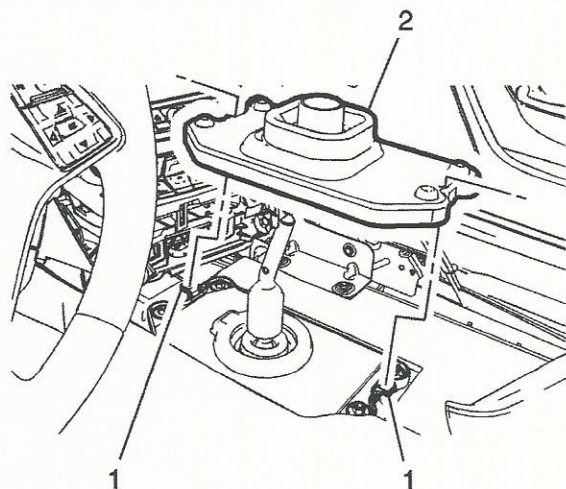

13. Install the upper closeout boot to the transmission control assembly.

**Important:** Ensure the upper closeout boot ID slides below the shifter stub can.

14. Install the front floor lower console. Refer to Front Floor Lower Console Replacement in SI.

### Warranty Information

For vehicles repaired under warranty, use:

Labor Operation	Description	Labor Time
8480128*	Transmission Control Adjustment	0.9 hr
*This is a unique Labor Operation for Bulletin use only. It will not be published in the Labor Time Guide.		

GM bulletins are intended for use by professional technicians, NOT a "do-it-yourselfer". They are written to inform these technicians of conditions that may occur on some vehicles, or to provide information that could assist in the proper service of a vehicle. Properly trained technicians have the equipment, tools, safety instructions, and know-how to do a job properly and safely. If a condition is described, DO NOT assume that the bulletin applies to your vehicle, or that your vehicle will have that condition. See your GM dealer for information on whether your vehicle may benefit from the information.



WE SUPPORT  
VOLUNTARY  
TECHNICIAN  
CERTIFICATION