



Service Bulletin

File in Section: 08 - Body and Accessories

Bulletin No.: 08-08-67-013H

Date: July, 2013

TECHNICAL

Subject: Snap, Pop, Creak or Rattle Noise from Lift Off Roof Panel While Driving
(Verify Condition and Perform Appropriate Repairs)

Models: 2005-2013 Chevrolet Corvette
Equipped with Removable Clear Roof Panel RPO CC3, Removable Sun Roof Panel
RPO CF7 or Dual Removable Roof Panels RPO C2L

This bulletin has been revised to add the 2013 model year and update the Labor Operation to the Global Labor Code (GLC). Please discard Corporate Bulletin Number 08-08-67-013G.

Important: Check the VIN to determine if the roof falls into the Safety Recall 06041D. On painted roofs, inspect the panel beneath the headliner. If the material is light gray in color, then the roof is Sheet Molded Compound (SMC) and is not in need of the recall. If the panel is charcoal in color, then the roof is Acrylonitrile/Butadiene-Styrene (ABS) and should have been involved with the recall. Follow the procedure outlined in the recall.

Important: If the roof is not involved in the recall or is the transparent roof, verify the roof is a GM roof. Check GMVIS to determine if the vehicle came with a painted or transparent roof. GMVIS will indicate option codes CF7 for a painted roof, CC3 for a transparent roof and C2L if the car was produced with both roofs.

Important: The intent of this bulletin is to identify the appropriate issue(s) and apply the appropriate correction(s) pertaining to the customer's comments. PLEASE VERIFY CUSTOMER CONCERN BEFORE SERVICE. Drive the vehicle and duplicate the complaint. Note where the noise is coming from, paying particular attention to the following specific areas of the roof:

- The rear center
- The rear outer edges
- The sides, above the door glass
- The front center
- The front edges

This bulletin covers the following issues:

- Clicking or popping noise coming from the rear area of the door (Refer to Condition #1)
- Roof weatherstrip itch (Refer to Condition #2)
- Snap, pop, creak, or rattle noise coming from the roof, rear center (Refer to Condition #3)

- Snap, pop, creak, or rattle noise coming from the roof, rear outer edges (Refer to Condition #4)
- Snap, pop, creak, or rattle noise from the roof sides, above the door window (Refer to Condition #5)
- Snap, pop, creak, or rattle noise from the roof near the windshield, at the front latch area (Refer to Condition #6)
- Snap, pop, creak, or rattle noise from the "A" pillar area (Refer to Condition #7)
- Change in lubrication to dielectric silicone grease as opposed to GM Super lube @ with PTFE

Condition #1

Some customers may comment of a clicking or popping noise coming from the rear area of the door.

Cause

There have been reported cases of a clicking noise coming from the door striker area. This condition may be a result of the door striker studs loosening slightly and flexing. Pinpoint the location of the noise by removing the lift off roof panel and driving the car with the windows in the full up position. If the noise is still present when the roof is removed, check the door striker.

Correction

Verify the striker is flexing by pulling outward on the striker and listening for a clicking noise. If the noise is evident, replace the striker. Refer to Door Striker Replacement in SI.

Condition #2

Important: The roof of the car is flexible and there is always some movement between the roof and the body. It is important to keep weatherstrips clean and lubricated to allow the roof to have movement without noise. The number one reason for noise in the roof area

is often found to be weatherstrip itch. Maintaining the weatherstrips is a customer responsibility. The frequency of cleaning and applying lubrication may vary from once a month, to once a season, depending on the environment and climate of vehicle operation.

Some customers may comment on an itch noise coming from the roof panel.

Cause #1

The roof weatherstrips may be dirty or lacking lubrication.

Cause #2

The customer may have applied a silicon spray such as Armor-all, or plastic cleaners, to the weatherstrips. These can leave a residue on the weatherstrip which may cause the roof to make noise.

Correction

1. Remove the lift off roof panel and clean all weatherstrips on the roof and the body with a mild soap and water solution.
2. Check weatherstrips for damage.

Important: Rub the lubrication into the weatherstrips until it is worked into the weatherstrip material. DO NOT leave a thick coating of lubrication on the weatherstrips as it will attract dirt and dust, and create an itch condition.

3. Apply a thin coating of dielectric silicone grease, GM P/N 12345579 (In Canada, P/N 10953481) to all weatherstrips.
4. Reinstall the roof panel.

Important: Test drive the car with the roof panel installed. If a noise is still present, note the particular area of the noise and use the following conditions/ guidelines to determine the necessary repair.

Condition #3

Some customers may comment of a snap, pop, creak, or rattle noise coming from the roof, rear center area.

Cause

This condition may be caused by any of the following:

- Insufficient clearance between the lift off roof panel and the leading edge of the rear roof bow.
- Possible crack at the rear edge of the lift off roof panel.
- Insufficient tension on the roof rear latching mechanism.

Correction

Important: There should be between 3-8 mm (0.120-0.315 in) of space between the lift off roof panel and the rear roof bow.

1. Verify there is sufficient gap, and that the lift off roof panel is not hitting the leading edge of the rear roof bow. If this condition exists, adjust the roof panel. Refer to Roof Lift Off Panel Adjustment in SI.
2. Inspect the rear edge of the lift off roof panel for cracks or chips. If a roof panel is dropped, or has been set down hard on the rear edge, it may crack the edge and cause a noise.

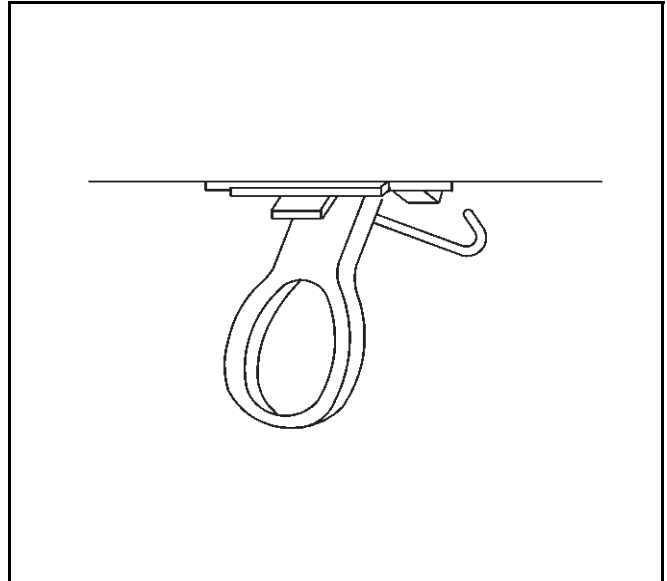

167241

3. Check the roof rear latching mechanism. The rear latch should have some resistance when the latch is closed, but it should not be difficult to release. If there is insufficient tension on the latch, the roof may be allowed to move too easily. Adjust the latch by unscrewing the set-screw and rotating the "J" hook of the latch inward to tighten, and outward to loosen. Tighten the set-screw after the "J" hook is adjusted.

Condition #4

Some customers may comment of a snap, pop, creak, or rattle noise coming from the roof, rear outboard edges.

Cause

The rear locator pins on the lift off roof panel may be loose, or someone may have attempted to adjust the height of the roof panel to this location.

Correction

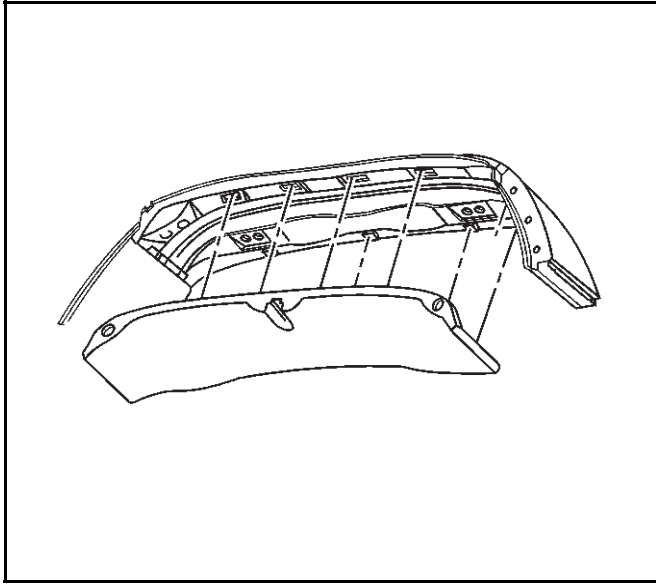

71202

1. Remove the rear roof bow trim panel. Refer to Rear Roof Bow Trim Panel Replacement in SI.

Important: Prior to alignment, ensure that the lift off roof panel rear locator bracket bolts are torqued to specification.

2. Verify proper alignment of the rear locator pins and the rear locators. Refer to Roof Lift Off Panel Adjustment in SI.

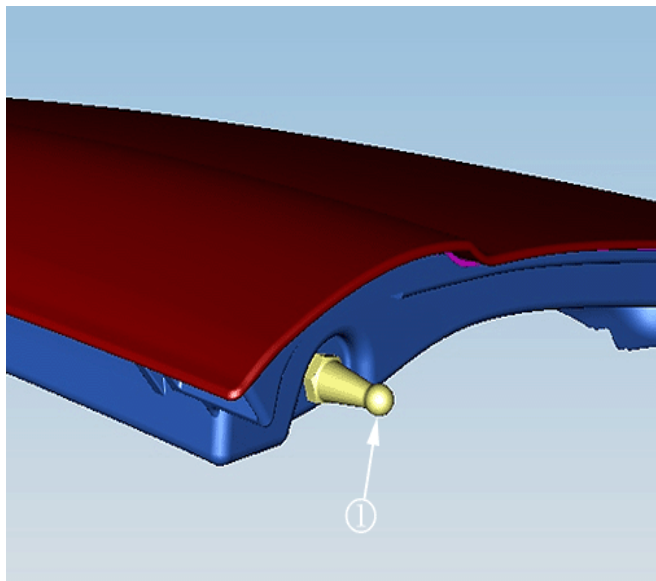

2170344

3. Apply a coating of dielectric silicone grease, GM P/N 12345579 (In Canada, P/N 10953481) to the rear locating pins (1) on the roof panel AND the rear locators on the roof bow. This will help to insulate the pins and prevent noise from radiating through the roof panel.
4. Reinstall the rear roof bow trim panel. Refer to Rear Roof Bow Trim Panel Replacement in SI.

Condition #5

Some customers may comment of a snap, pop, creak, or rattle coming from the side of the roof, above the door window.

Cause

The upper edge of the door windows may be contacting one or more of the screws that attach the roof weatherstrip retainers to the lift off roof panel. To verify this condition, lower the windows approximately 12.7 mm (0.500 in) and test drive the car. If the noise is still present, move ahead to the next condition.

Correction

Inspect the front leading edge of the door windows on both sides for evidence of contact with these screws. This is best done by completing the following steps:

1. Lower both door windows and run your fingernail across the edge of the glass, feeling for chips.
2. If a chip is detected, place a crayon mark on the window below the chip so it can be seen when the window is in the full up position.
3. Close the door, raise the window and note the position of the crayon mark at the weatherstrip.
4. Open the door and check that location for a screw in the weatherstrip retainer. Ensure that the screw is fully seated and there are no burrs on the screw head.
5. Reseat the screw or adjust the door window down to make sure the window is no longer contacting the screw. Check that all weatherstrip retainer screws are fully seated.

Condition #6

Some customers may comment of a snap, pop, creak, or rattle noise coming from the roof near the windshield, at the front latch area.

Cause

This condition may be caused by the nylon roller/slide block inside the left and/or right front roof panel latching handle becoming loose and causing the roller to move on the pin, creating the noise.

Correction

Important: For any latch handle replacement, use only P/N 19206591 (left) and P/N 19206592 (right). These current handles have a revised roller that was redesigned so it does not roll, but now slides across the latch receiver. All 2009-2013 removable roofs (painted and transparent) have the new handle design. **Handles should not be changed for vehicles built after the beginning of production for the 2009 model year.**

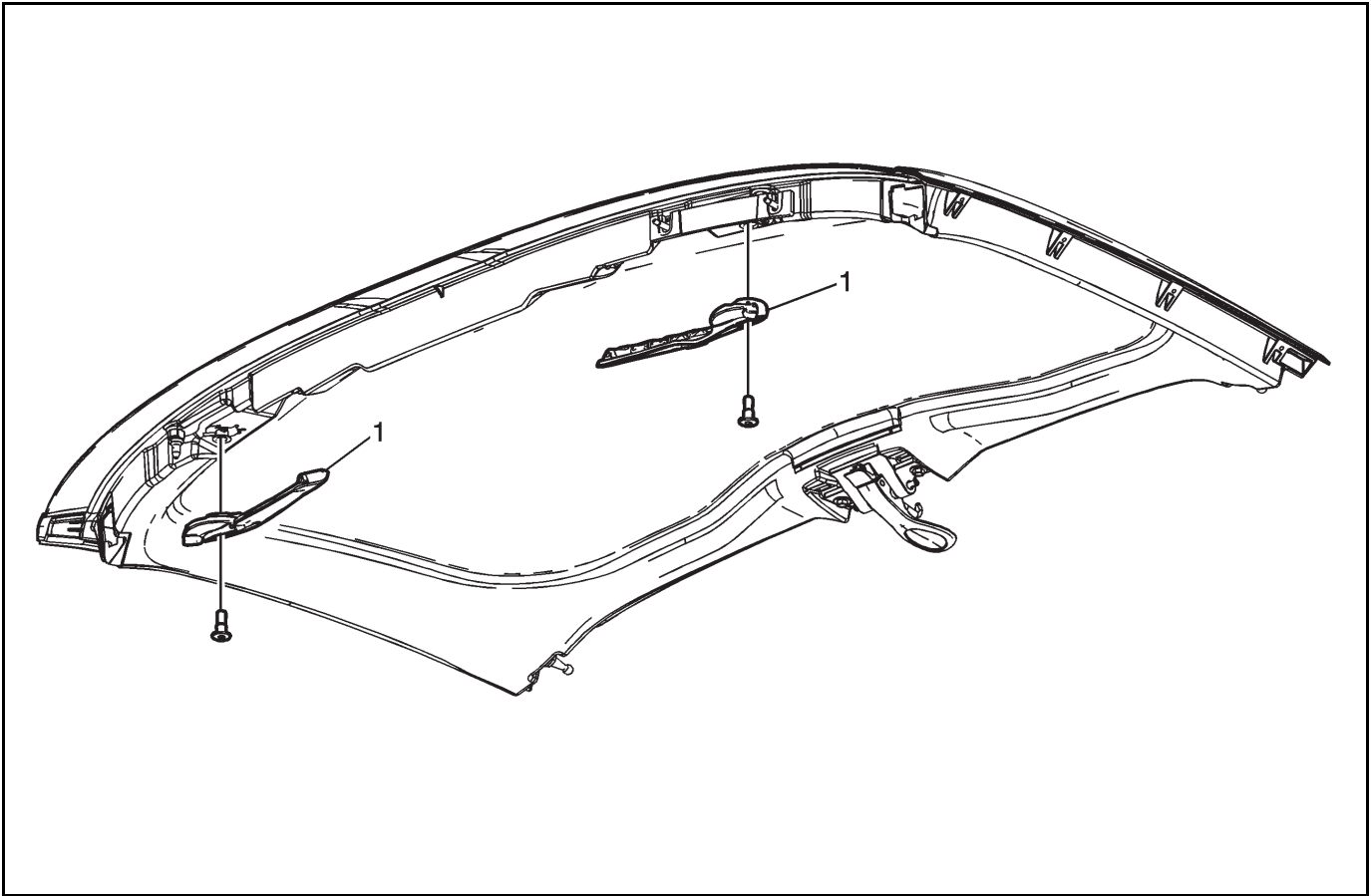

2128668

1. If the noise is verified to be coming from the front latch area, inspect the handle roller. Identify the design, and the resulting repair, from the two choices below:

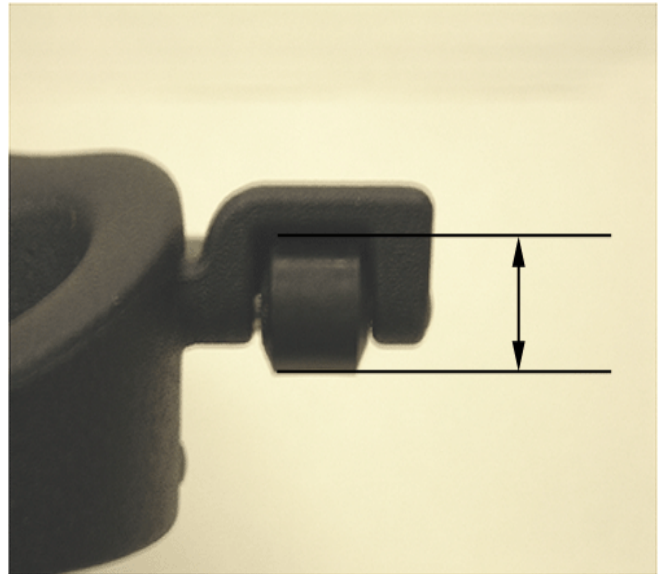

2236147

- If the roller is round and will spin on its axis (as shown above), they are early design handles and should be replaced. Replace the left and right front lift off roof panel handles with the current handle design parts noted previously, **and include the lubrication steps below.** Refer to Roof Lift Off Panel Front Latch Handle Replacement in SI.

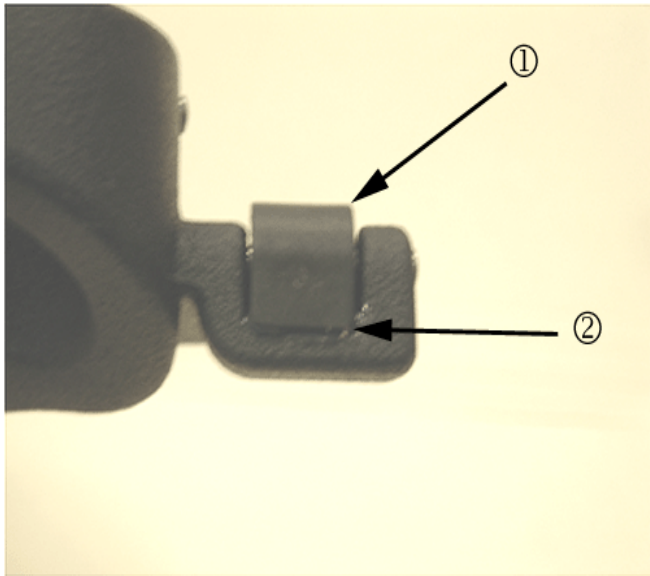

2236148

Important: Unless there is a concern with the handles or the roller, there is no need to replace the latch handles if they are of the current design.

- If the roller is rounder on the contact side (1), and is flat and secured on the latch side (2), they are current design and DO NOT need replacement.



2537153

Important: Before proceeding with the lubrication, inspect the roller area for any excessive glue (as shown in the graphic above). If found, remove the excess glue with a sharp knife.

2. Whether the latch handles are replaced or the vehicle already has the current design, apply lubrication following the steps below:
 - 2.1. Add a small amount of dielectric silicone grease, GM P/N 12345579 (In Canada, P/N 10953481) to the barrel of the handle attaching bolt. DO NOT get grease on the bolt threads as it will reduce the effectiveness of the tread locking compound.

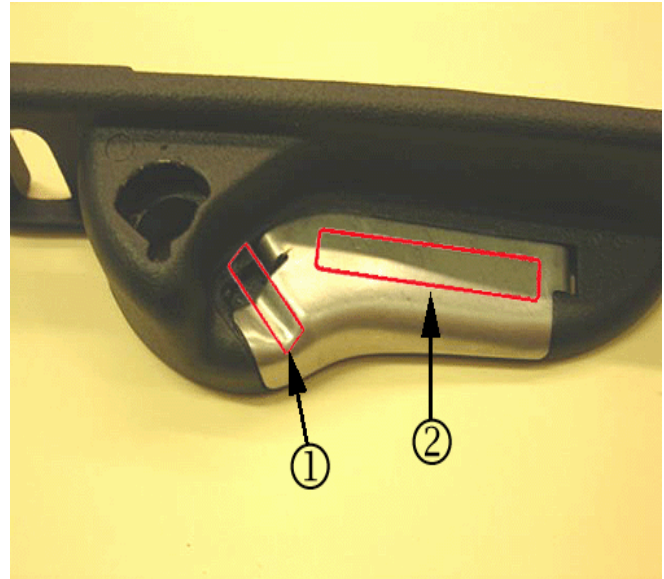

2236151

Important: Verify that the steel plate on the underside of the latch receiver is secured to the receiver. If any motion is detected when the plate is moved up or down, replace the receiver. **Because both of the receivers are adjustable up and down, make note of the location of the receiver plate prior to removing it.** Too much downward pressure may cause the roof to make noise, and too little can create a wind noise/ water leak.

- 2.2. Always make sure there is a thin coat of dielectric silicone grease, GM P/N 12345579 (In Canada, P/N 10953481), on the underside of the latch receiver along the path of the roller (2). Also apply a thicker 1 mm (0.040 in) coating where the roller rests when the latch is closed (1).
3. After the latch handles have been installed and before reinstalling the roof panel, check the right and left front latch receiver inserts.

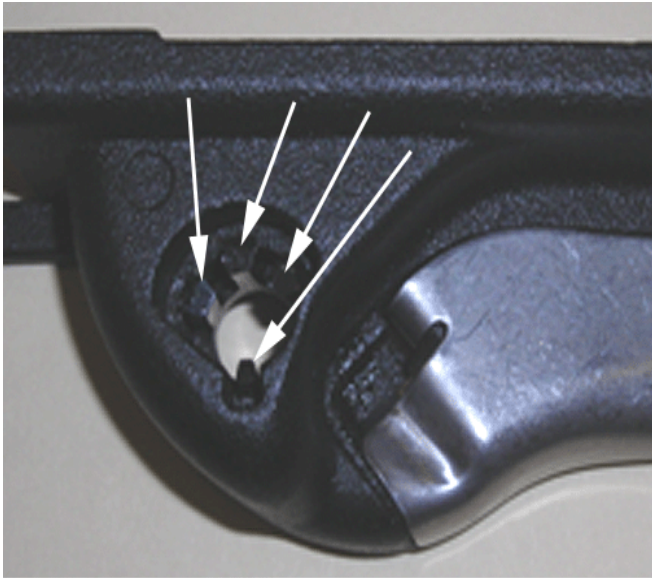

2236149

- 3.1. These can be removed by carefully using a thin blade screwdriver from the underside, and moving the four locking tabs toward the center and pushing the inserts up.

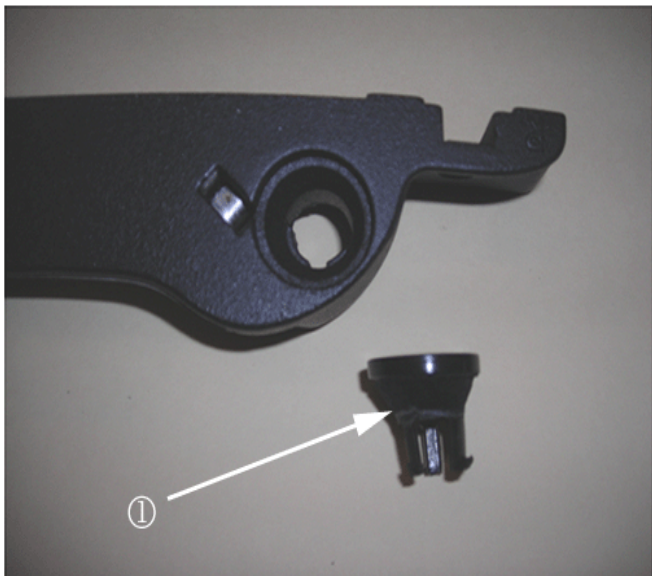

2236150

- 3.2. Once removed, inspect each insert (1) to verify the cones are not cracked or broken.

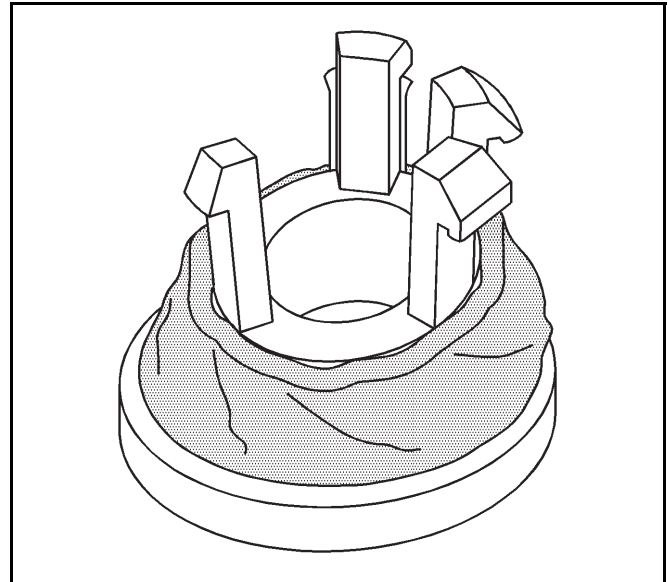

1935499

Note: The flocking is designed to insulate the cone when roof movement occurs.

- 3.3. Also verify that the inserts have an 8 mm (0.31 in) wide wrap of flocking tape toward the top of the cone, as shown above. If the flocking tape is worn or is missing, repair following the latest version of Corporate Bulletin Number 05-08-59-003.

Condition #7

Some customers may comment of a snap, pop, creak, or rattle noise coming from the "A" pillar area.

Cause #1

The windshield side garnish moldings may be causing the noise.

Cause #2

The windshield upper garnish molding guides or the windshield header wiring harness may be causing the noise.

Correction

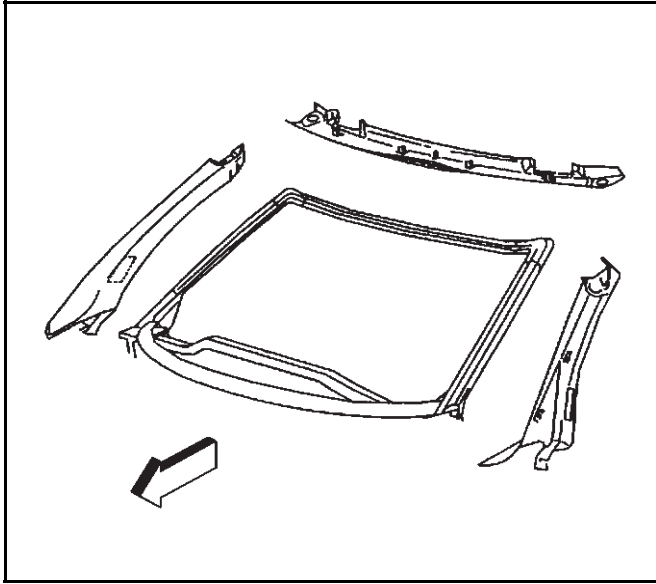

71178

1. Remove the upper and both side windshield garnish moldings. Refer to Windshield Upper Garnish Molding Replacement in SI.
2. Follow the latest version of Corporate Bulletin Number 05-08-59-003 to add flocking tape to the "A" pillar garnish moldings.

Note: There are electrical wires that run behind the windshield header. There have been some comments about the wire harness vibrating inside the windshield header.

3. Add a piece of foam insulation through the holes where the wire harnesses exit to help prevent the harnesses from rattling under vibration.

Note: There are three molded guides that protrude from the back side of the windshield upper garnish molding.

4. While the windshield upper garnish molding is off, check these guides for any signs of contact. If there is evidence of contact, sand or file the pins shorter to prevent the contact.
5. Reinstall the windshield garnish moldings. Refer to Windshield Upper Garnish Molding Replacement in SI.

Parts Information

Order the left and right handle for each lift off roof panel.

Part Number	Description
19206591	Handle, Roof Lift Off Panel – Left
19206592	Handle, Roof Lift Off Panel – Right
12345579 (U.S.) 10953481 (Canada)	Dielectric Silicone Grease

Warranty Information

For vehicles repaired under warranty, use:

Labor Operation	Description	Labor Time
6080048*	Handle, Lift Off Roof – Front – Both – Replace	0.4 hr
Add	Second Lift Off Roof Panel Handle – Front – Both – Replace	0.3 hr
Add	Apply Dielectric Silicone Grease	0.1 hr

*This is a unique labor operation for bulletin use only. It will not be published in the Labor Time Guide.